







## EWA4001ZZ

### Features

-  Broadband Performance: 18 to 40 GHz
-  Dynamic Range: 22 dB, typical
-  Input IP3: +20 dBm, typical
-  Dual Voltage Control: -1.5 to 0 V
-  100% RF and DC tested
-  Die Size: 1.5 x 1.5 x 0.1 mm

### Device Photo

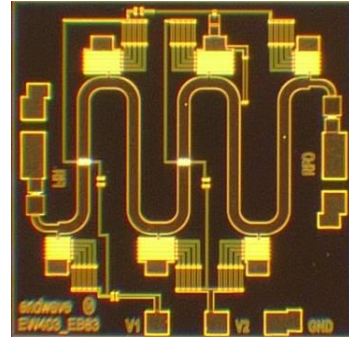

### Description

The Endwave *EWA4001ZZ* is a 0.15um GaAs pHEMT broadband voltage variable attenuator MMIC. The high linearity voltage variable attenuator provides 22 dB dynamic range with +20 dBm input IP3 at any attenuation. The chip may be used for a wide range of applications from defense electronics to commercial communication systems. All parts are 100% DC and RF tested and visually inspected using Mil-Std-883 Method 2010.

### Block Diagram

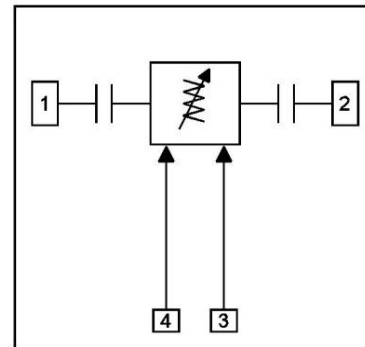

### Electrical Characteristics (Temperature = +25 °C)

Parameter	Min.	Typ.	Max.	Units
Frequency Range	18		40	GHz
Minimum Insertion Loss	1.6		3.7	dB
Dynamic Range @ 18 GHz		22		dB
Input Return Loss (over dynamic range)		7		dB
Output Return Loss (over dynamic range)		8		dB
Input IP3 (any attenuation)		20		dBm
Gain control Voltage <sup>1</sup> (Vctrl 1,2)	-1.5		0	V

Note 1: Max attenuation for Vctrl 1, 2 = 0 volts

## EWA4001ZZ

**Attenuation vs. Frequency  
18 – 40 GHz**

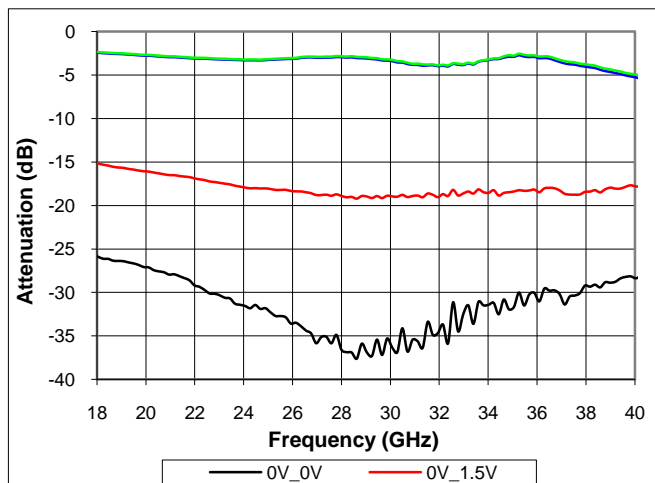

**Return Loss vs. Frequency  
18 – 40 GHz**

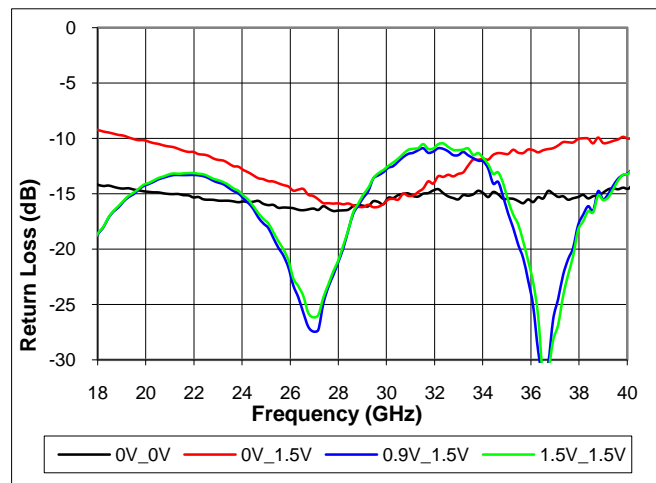

**Attenuation vs. Frequency  
36 – 40 GHz**

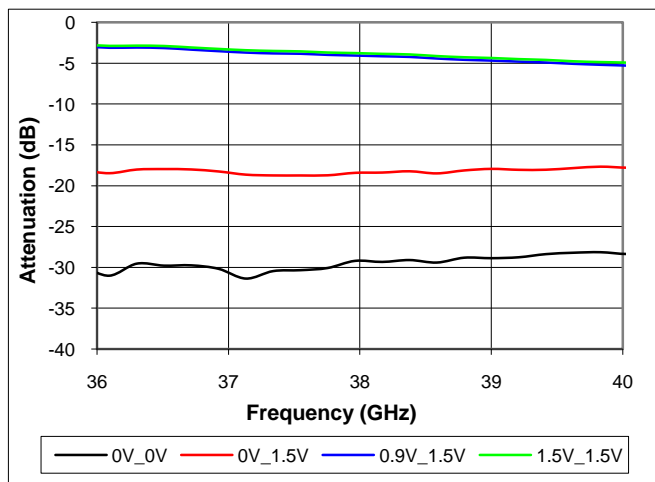

**Return Loss vs. Frequency  
36 – 40 GHz**

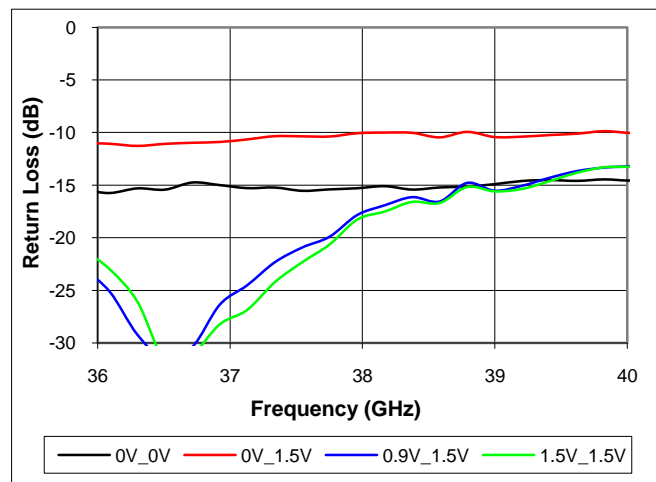

**Attenuation vs. Frequency  
30 – 34 GHz**

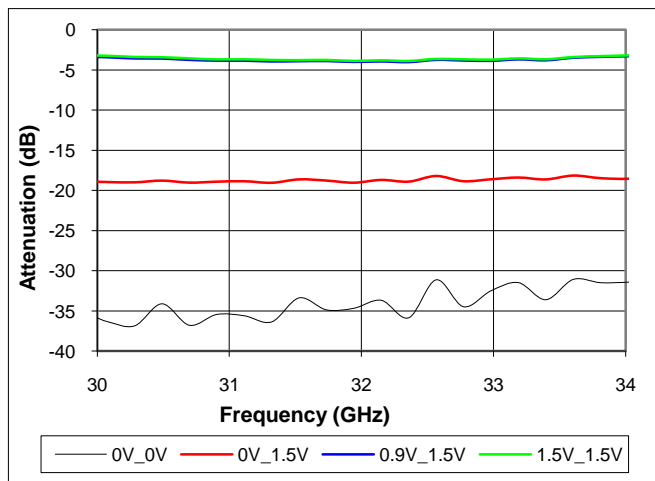

**Return Loss vs. Frequency  
30 – 34 GHz**

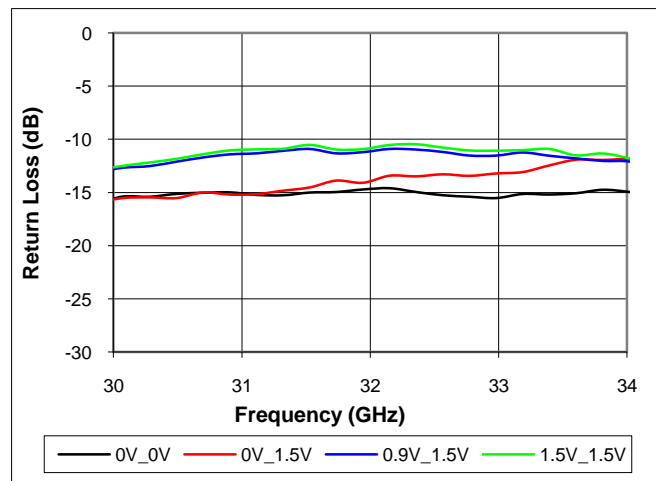

## EWA4001ZZ

Attenuation vs. Frequency  
26 – 30 GHz

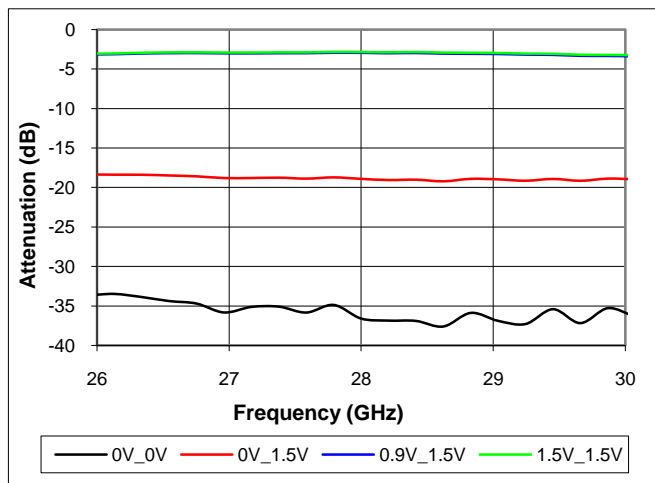

Return Loss vs. Frequency  
26 – 30 GHz

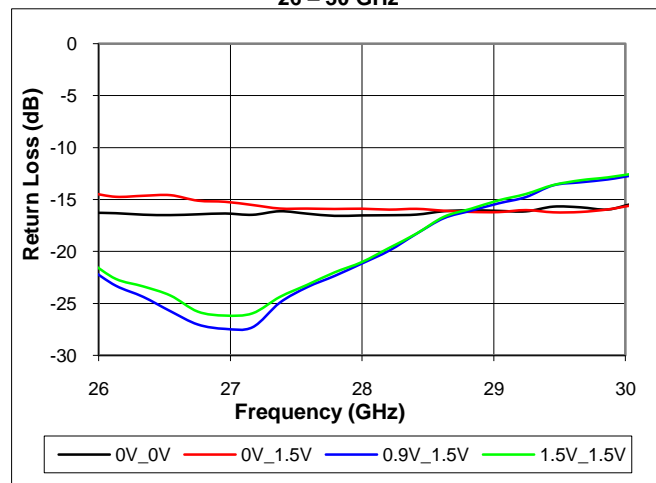

Attenuation vs. Frequency  
24 – 28 GHz

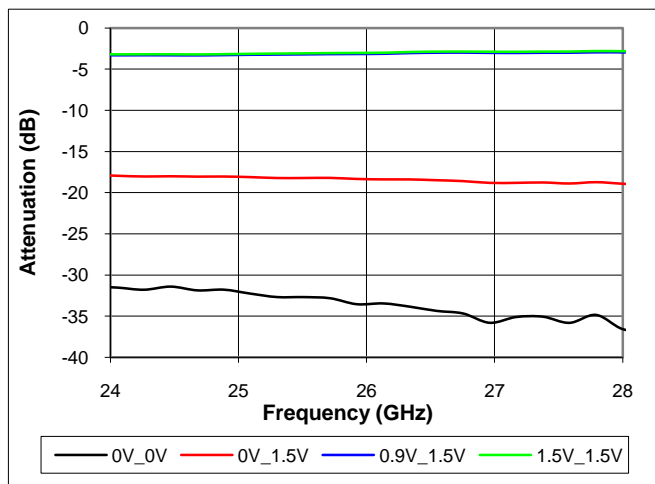

Return Loss vs. Frequency  
24 – 28 GHz

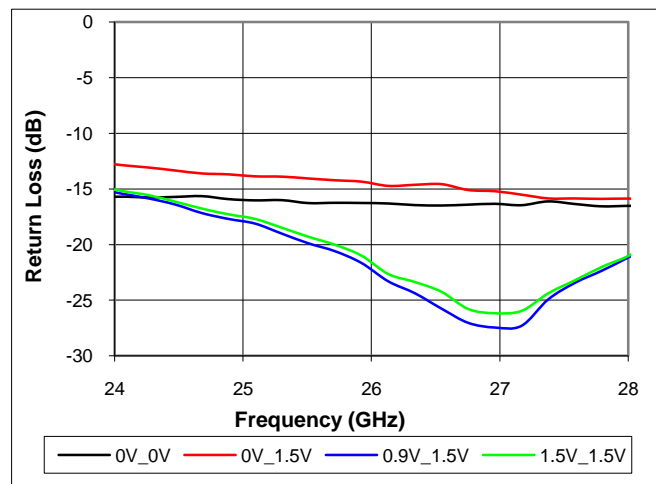

Attenuation vs. Frequency  
21 – 25 GHz

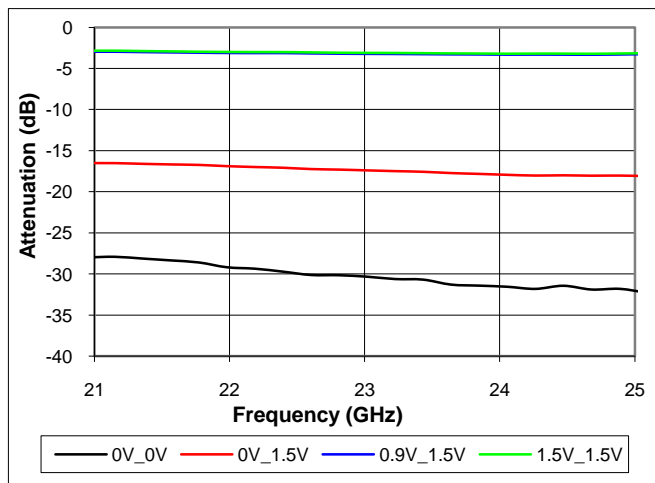

Return Loss vs. Frequency  
21 – 25 GHz

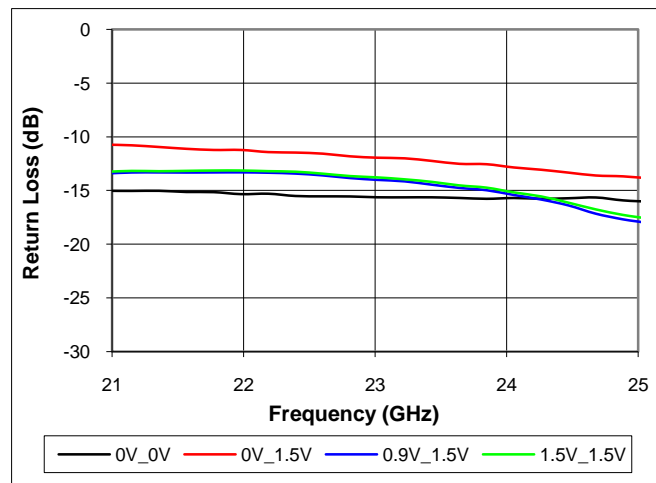

Input IP3 vs V2 (V1 = -1.5)

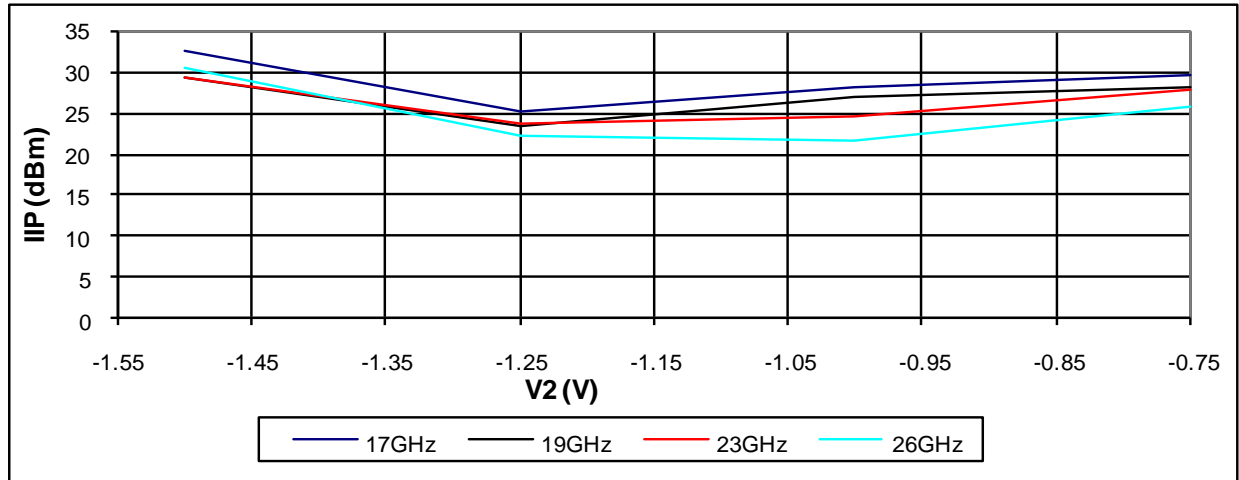

Input IP3 vs V1 (V2 = -1.5)

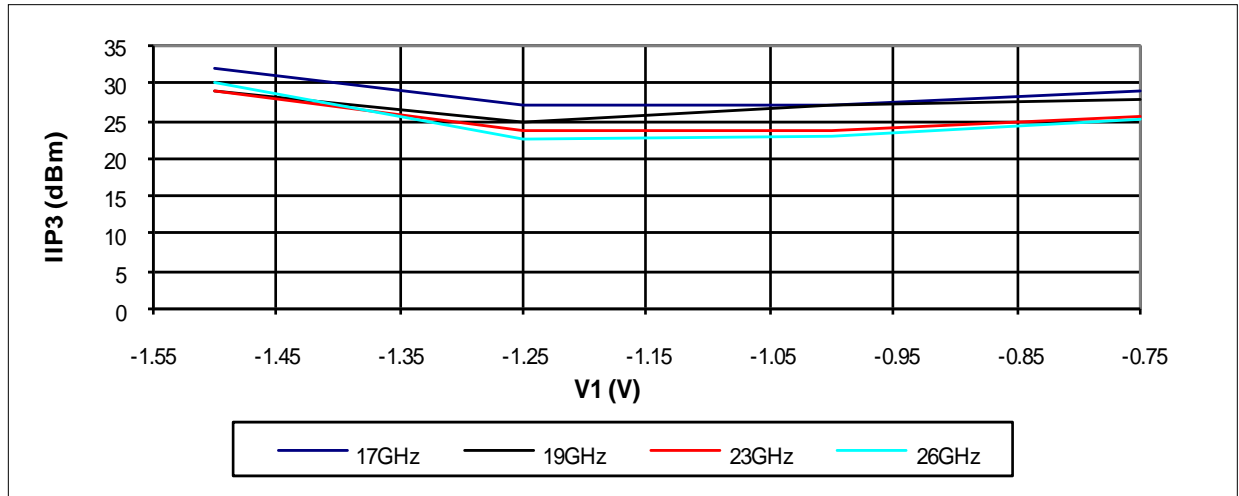

Input IP3 vs V2 & V1

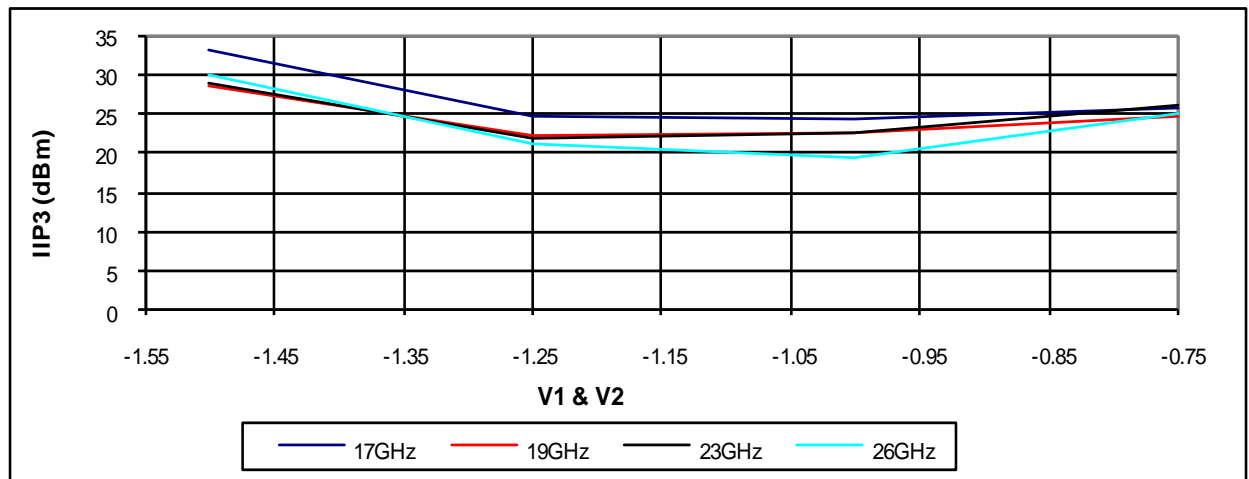

### Assembly Drawing

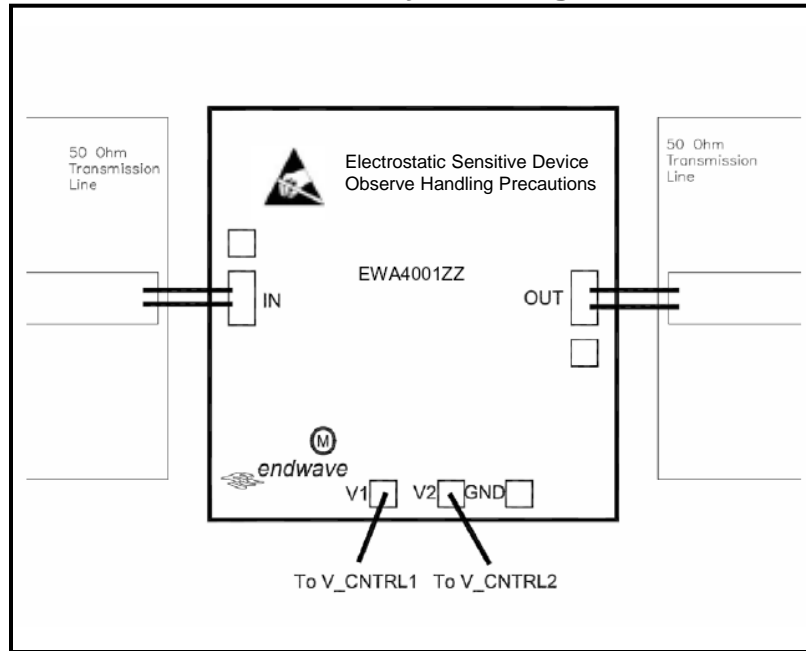

### Outline Drawing

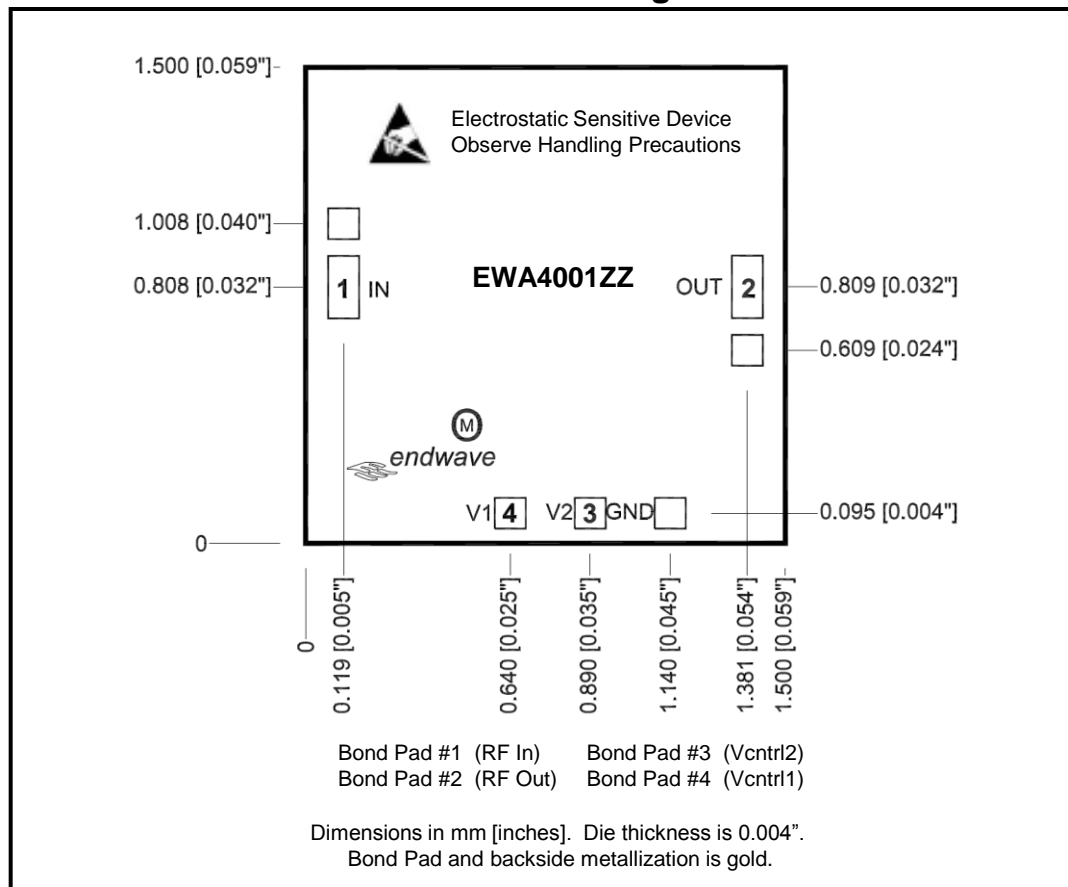

### Absolute Maximum Ratings

RF Input Power (min attenuation)	+25 dBm
Control Voltage (Vctrl1, 2)	-2.5 V to 0V
Storage Temperature	-65 to +150°C
Operating Temperature	-40 to +85°C

### Typical Application

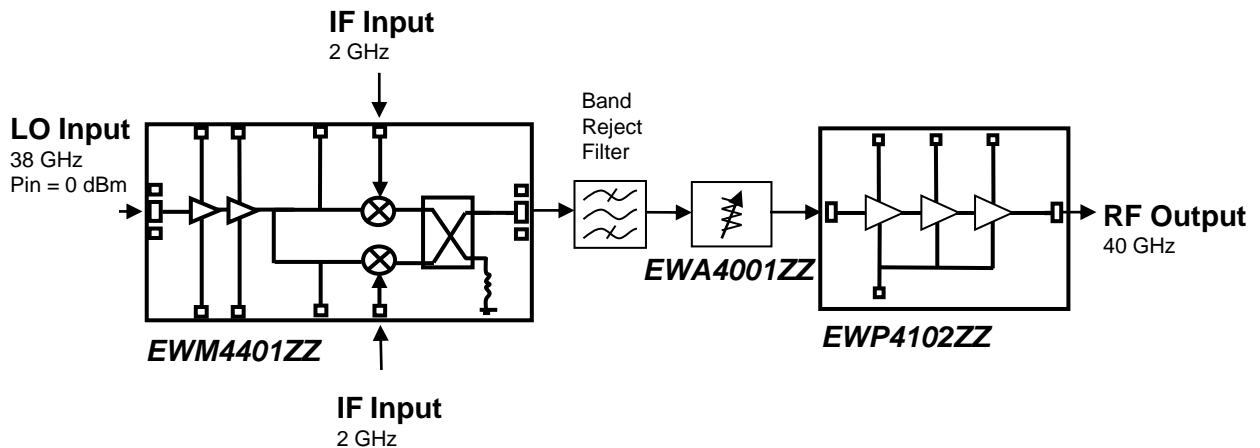

### Support Documentation

Support documentation including Assembly Notes, Application Notes and Qualification Procedures can be found on our website at [www.endwave.com](http://www.endwave.com).

### Ordering Information

**Part Number**  
EWA4001ZZ

**Description**  
RoHS Compliant Bare die in waffle or gel packs