









Features

-  Integrated VVA and RF Amp
-  RF Bandwidth: 17.7 – 23.6 GHz
-  Maximum Gain: 11 dB typical
-  Dynamic Range: 53 dB typical
-  Output IP3: +25 dBm (max gain)
-  Output P1dB: +15 dBm (max gain)
-  100% RF and DC tested
-  Die Size: 3.8 x 2.1 x 0.1 mm

Device Photo

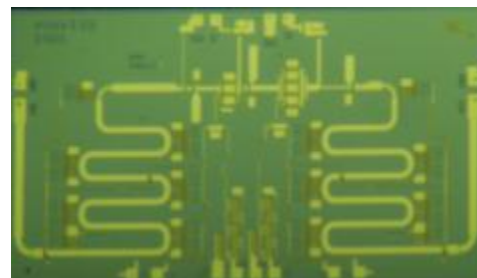

Description

The Endwave *EWG2303ZZ* is a highly integrated 0.15um GaAs pHEMT variable gain amplifier MMIC which provides 11 dB of gain and 53 dB dynamic range with +25 dBm output IP3 at maximum gain. The high dynamic range is achieved through the use of a pair of voltage variable attenuators at the input and output of a fixed gain amplifier. The chip may be used for a wide range of applications from defense electronics to commercial communication systems. All parts are 100% DC and RF tested and visually inspected using Mil-Std-883 Method 2010.

Block Diagram

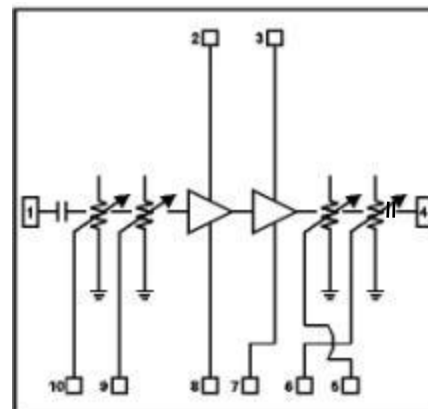

Electrical Characteristics (Temperature = +25 °C)

Parameter	Min.	Typ.	Max.	Units
Frequency Range	17.7		23.6	GHz
Gain (Max for Vctrl 1, 2, 3, 4 = -1.5 V)		11		dB
Dynamic Range (Gmax – Gmin)		53		dB
Input Return Loss (over dynamic range)		8		dB
Output Return Loss (over dynamic range)		10		dB
Output IP3 (min attenuation)		25		dBm
Gain Control Voltage (Vctrl 1, 2, 3, 4)	-1.5		0	V
Drain Bias Voltages (Vd 1, 2)		4.5		V
Drain Bias Currents (Id1 + Id2)		235		mA
Gate Bias Voltages (Vg1, Vg2)		-0.6		V

Note 1: Min gain for Vctrl 1, 2, 3, 4 = 0 volts

VGA Gain vs. Frequency
(V1/V2 Gain Control; Fixed V3/V4 = -1.5 V)

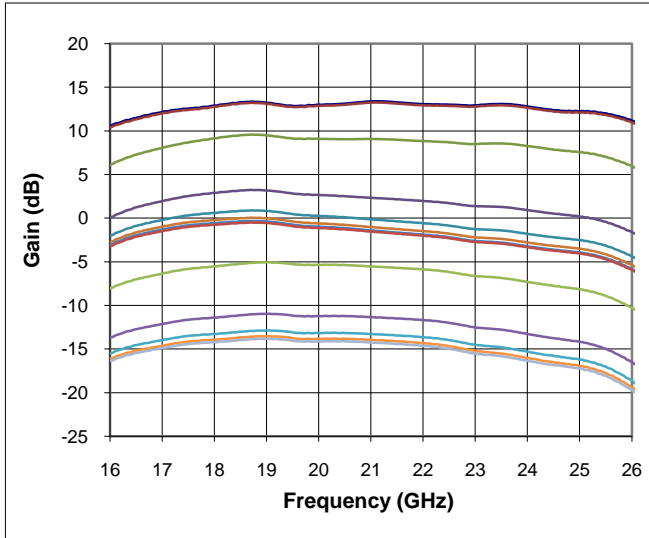

VGA Input Return Loss vs. Frequency
(V1/V2 Gain Control; Fixed V3/V4 = -1.5 V)

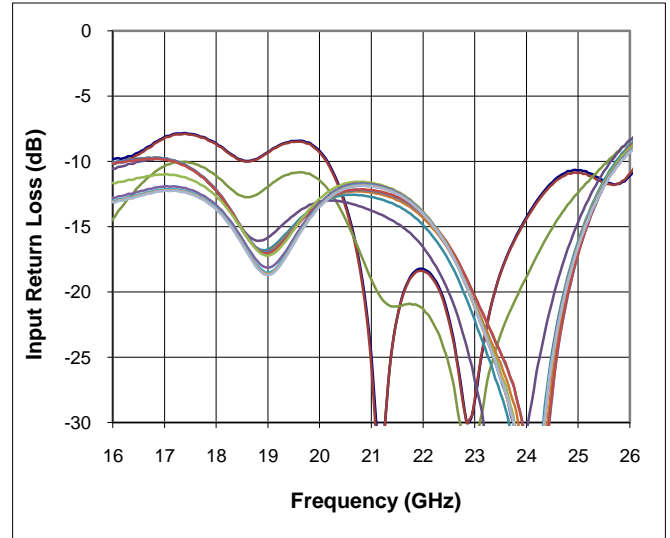

VGA Output Return Loss vs. Frequency
(V3/V4 Gain Control; Fixed V1/V2 = -1.5 V)

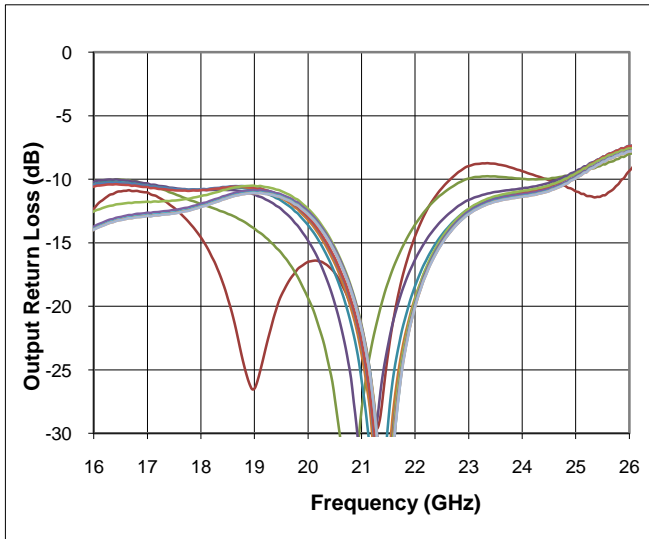

OIP3 vs. Gain
(V1/V2 Gain Control; Fixed V3/V4 = -1.5 V; Pin = 0 dBm)

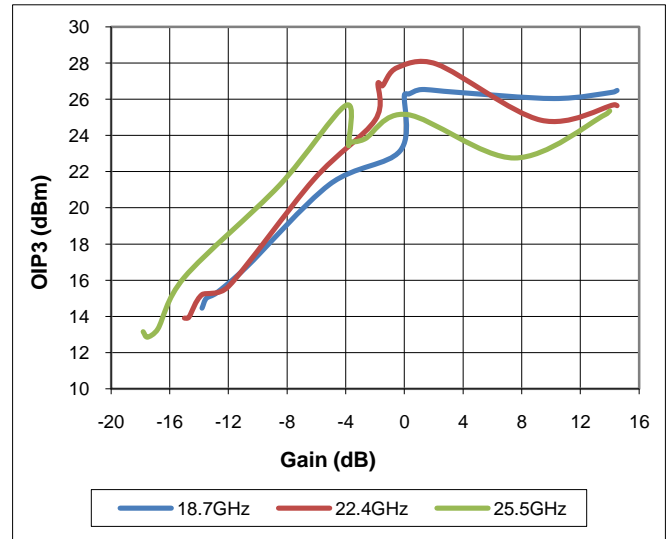

Assembly Drawing

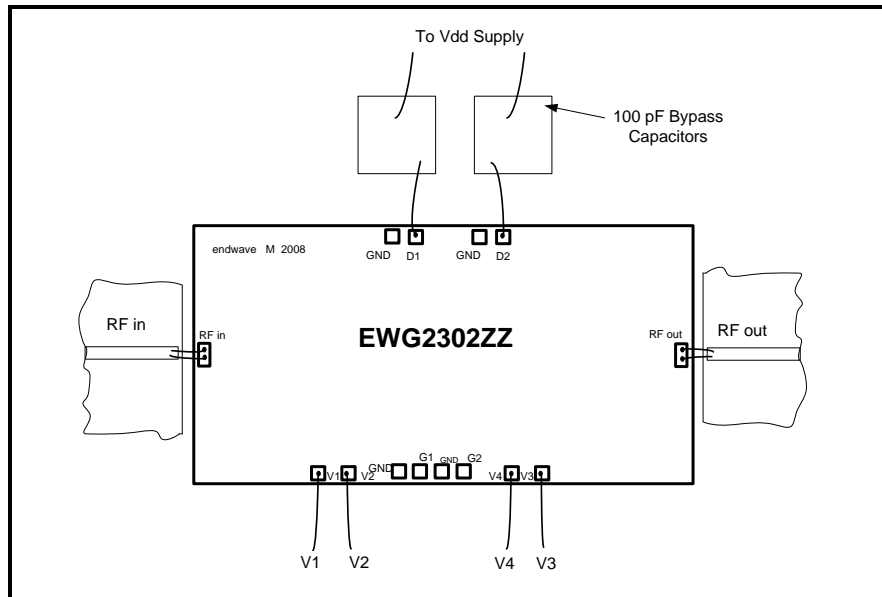

Outline Drawing

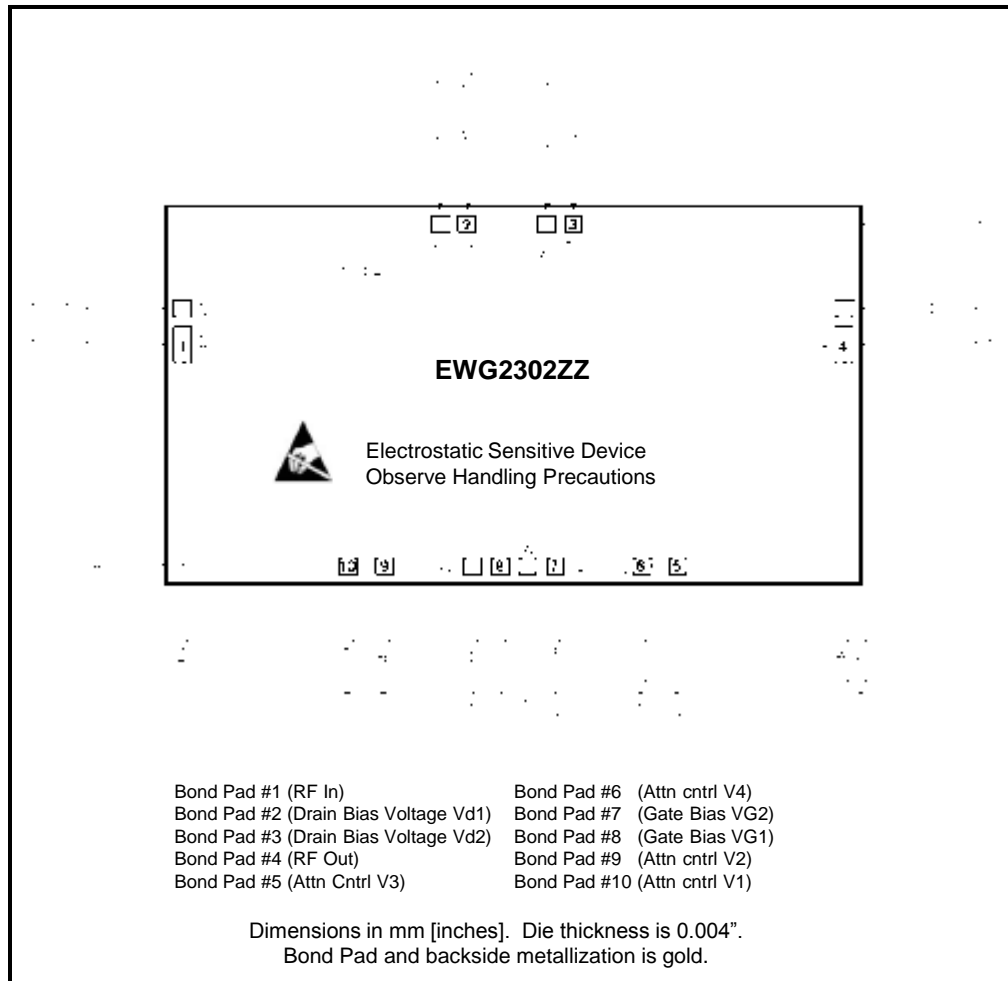

EWG2303ZZ

September 2009 – Rev 1

Production

Absolute Maximum Ratings

RF Input Power (max gain)	+18 dBm
Supply Voltage (Vd1, 2)	+5.5 V
Supply Current (Id1+Id2)	450 mA
Supply Voltage (Vg1, 2)	-2.5 to 0V
Control Voltage (Vctrl1, 2, 3, 4)	-2.5 to 0V
Storage Temperature	-65 to +150°C
Operating Temperature	-40 to +85°C
Channel Temperature	175°C

Typical Application

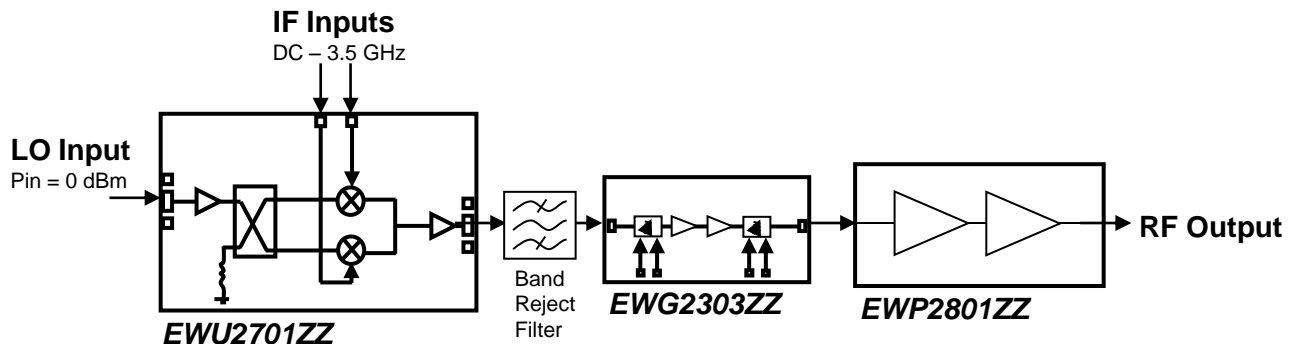

Support Documentation

Support documentation including Assembly Notes, Application Notes and Qualification Procedures can be found on our website at www.endwave.com.

Ordering Information

Part Number	Description
EWG2303ZZ	RoHs Compliant bare die in waffle or gel packs