









EWM8601ZZ

November 2009 – Rev. 1

Production

Features

-  Sub-harmonically Pumped Mixer (2LO)
-  Broadband Performance: 81 - 86 GHz
-  Input P1dB: +8 dBm
-  Conversion Loss: 11 dB typical
-  LO Drive Level: +18 dBm typical
-  100% RF and DC tested
-  Die size: 1.49 x 2.59 x 0.227 mm, height includes flipped diodes
-  MLMS™ Technology Provides Excellent Performance and Repeatability

Device Photo

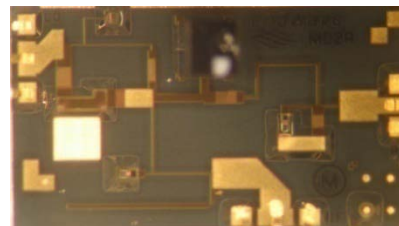

Description

The Endwave *EWM8601ZZ* is a high performance MLMS™ subharmonic mixer which provides conversion loss of 11 dB, RF return loss at better than 13 dB, and excellent performance repeatability. The chip may be used for a wide range of Eband applications from defense electronics to commercial communication systems. All chips are visually inspected using Mil-Std-883 Method 2010.

Block Diagram

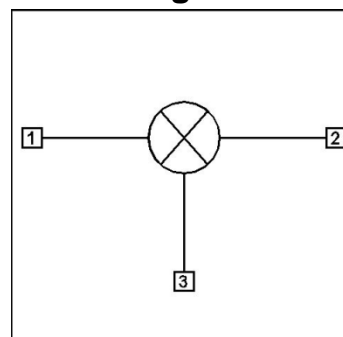

Electrical Characteristics (Temperature = +25 °C)

Parameter	Min.	Typ.	Max.	Units
Frequency Range, RF	81		86	GHz
Frequency Range, IF	DC		15	GHz
Frequency Range, LO	25		45	GHz
Conversion Loss ^(1,2)		11		dB
Output P1dB Compression		-2		dBm
LO Drive Power		17		dBm
IF Return Loss		6		dB
LO Return Loss		6		dB
RF Return Loss		13		dB

Note1: Measured as Upconverter

Note2: Measured as Downconverter

High Band Mixer: Conversion Loss vs. Frequency
LO = 36 GHz and IF = 9 to 14 GHz

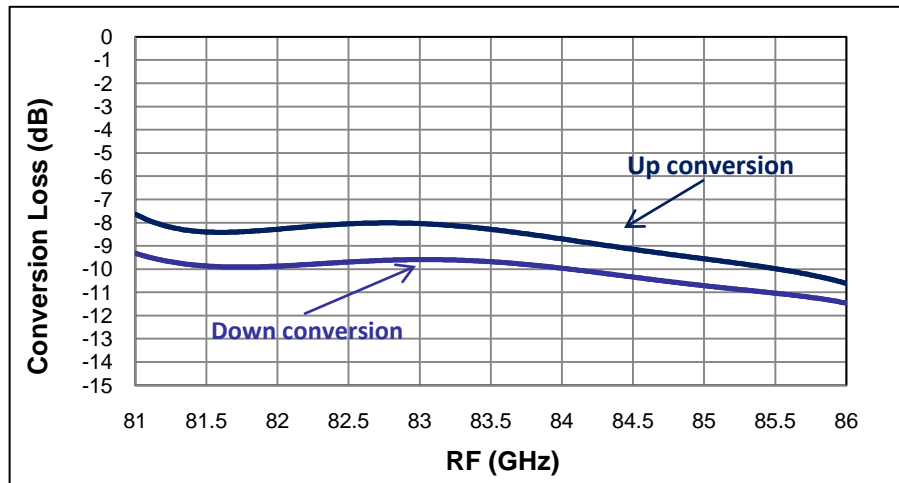

High Band Mixer: Pin vs. Pout
RF = 86 GHz, LO = 36 GHz, and IF = 14 GHz

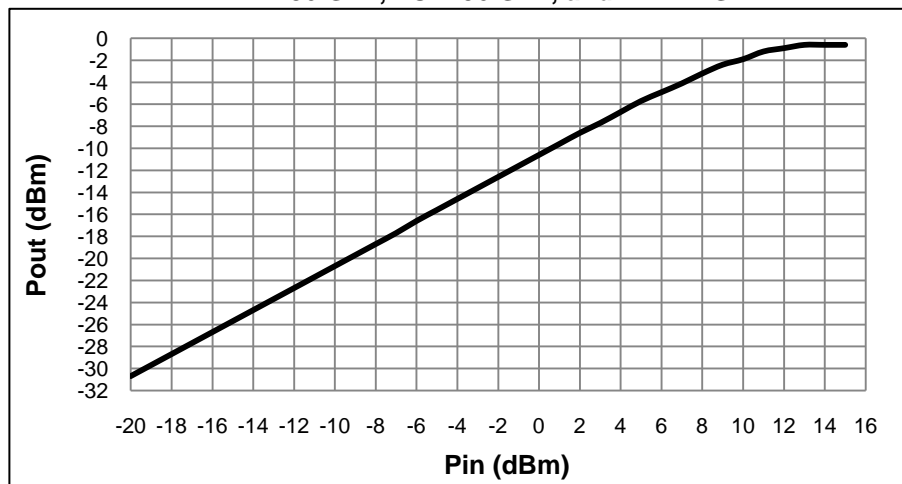

High Band Mixer: Conversion Loss vs. LO Driver Power
RF = 83.6 GHz, LO = 35.2 GHz, and IF = 13.2 GHz

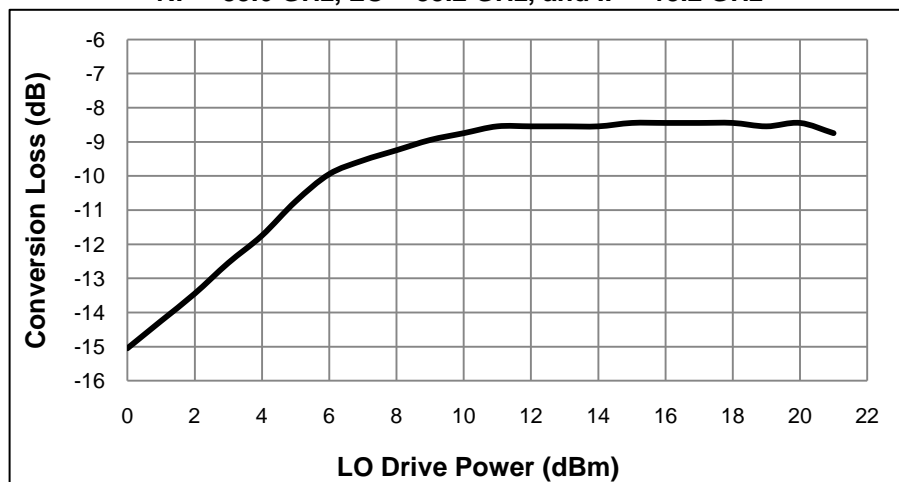

MLMS™ Mixers -- Chip

High Band Mixer: Return Loss vs. Frequency

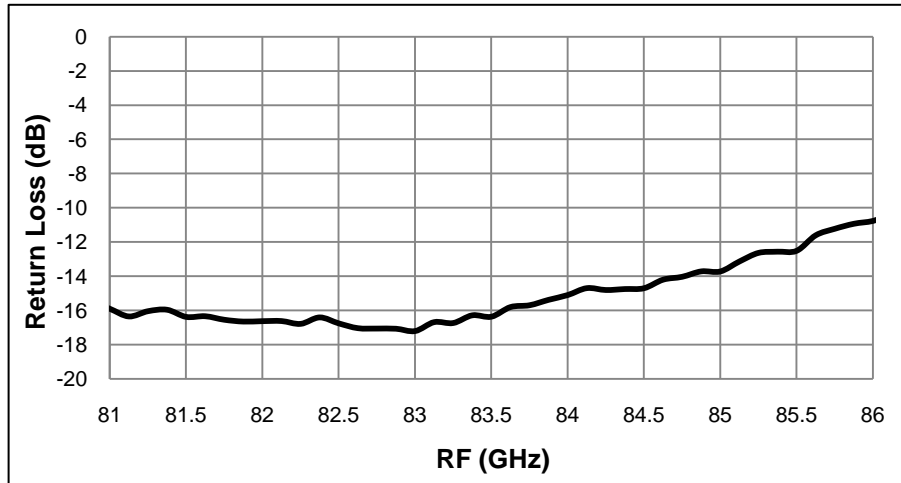

IF Return Loss

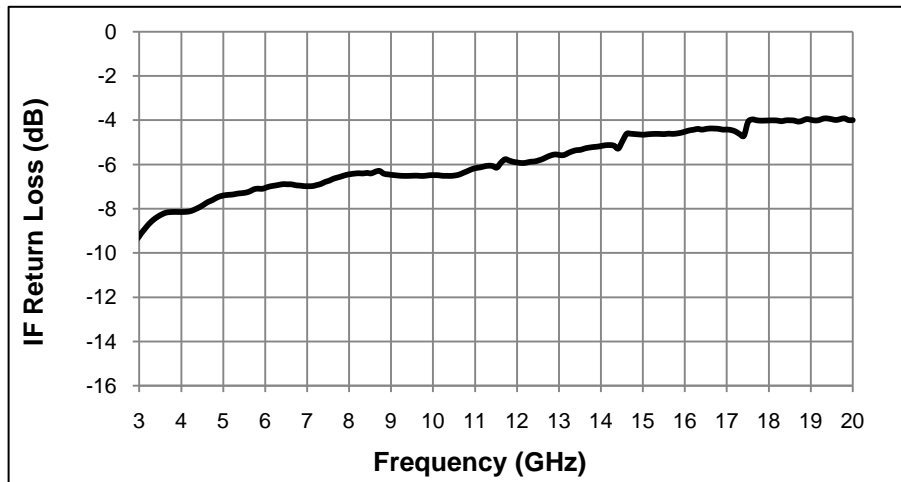

LO Return Loss

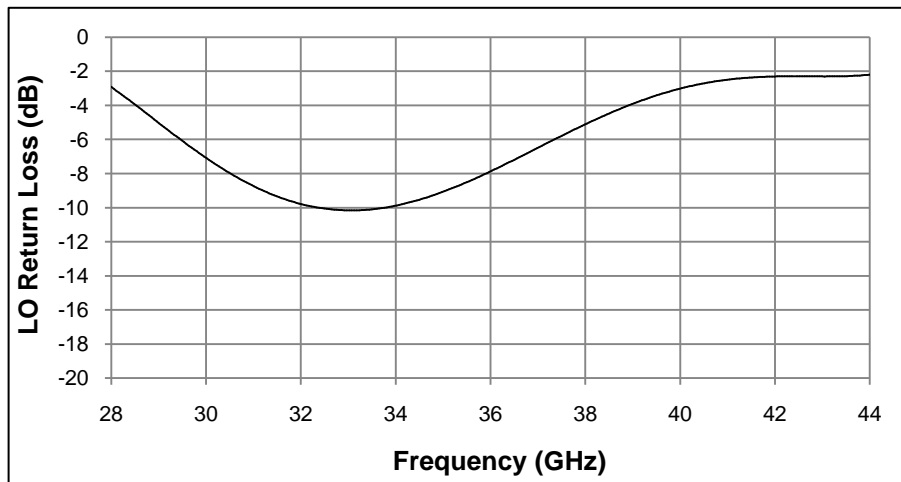

Assembly Drawing

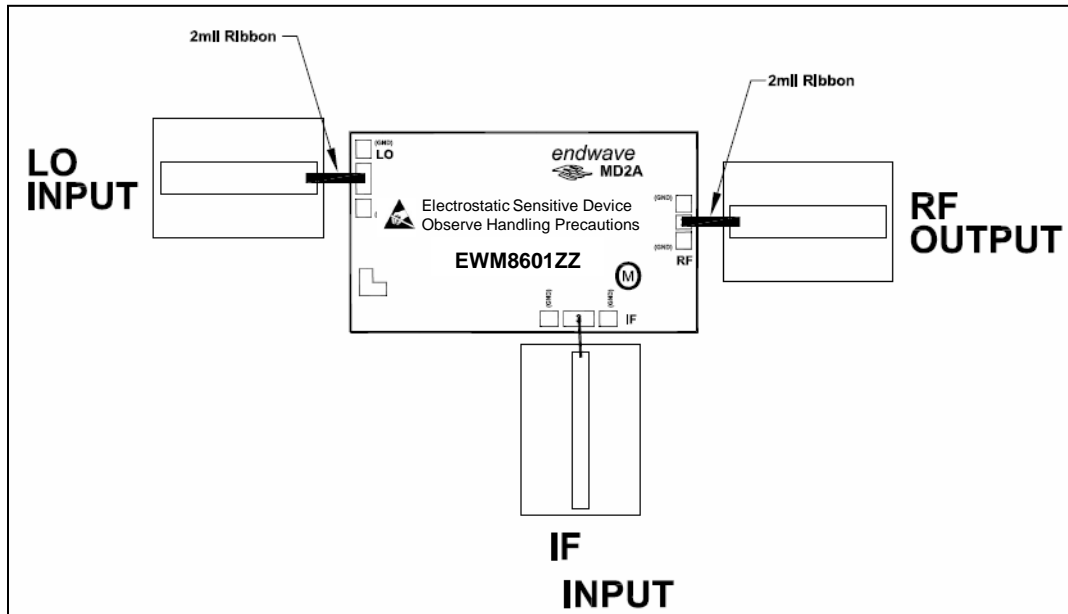

Note: Optimum performance can be achieved by coplanar bonding.

Outline Drawing

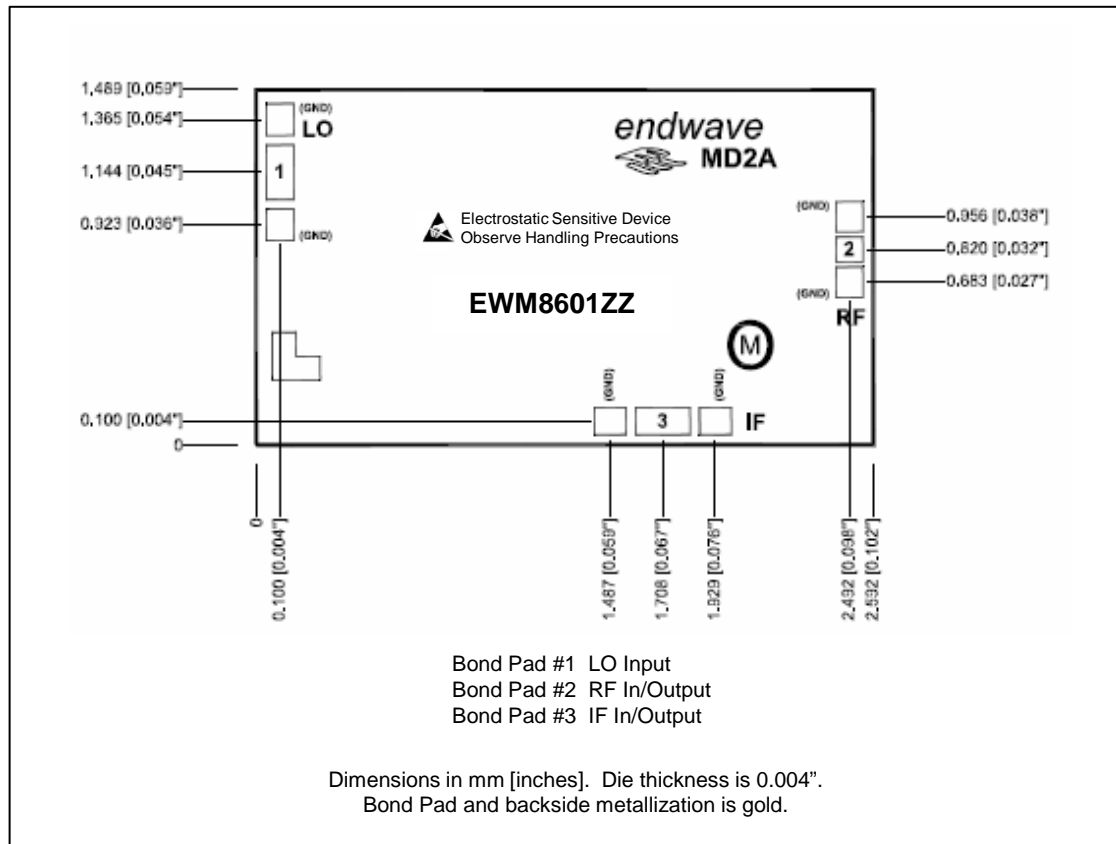

MLMS™ Mixers -- Chip

Absolute Maximum Ratings

IF Input Power	+ 21 dBm
LO Input Power	+ 21 dBm
RF Input Power	+ 21 dBm
Storage Temperature	-65° to +150°C
Operating Temperature	-40° to +85°C

Typical Upconverter Application

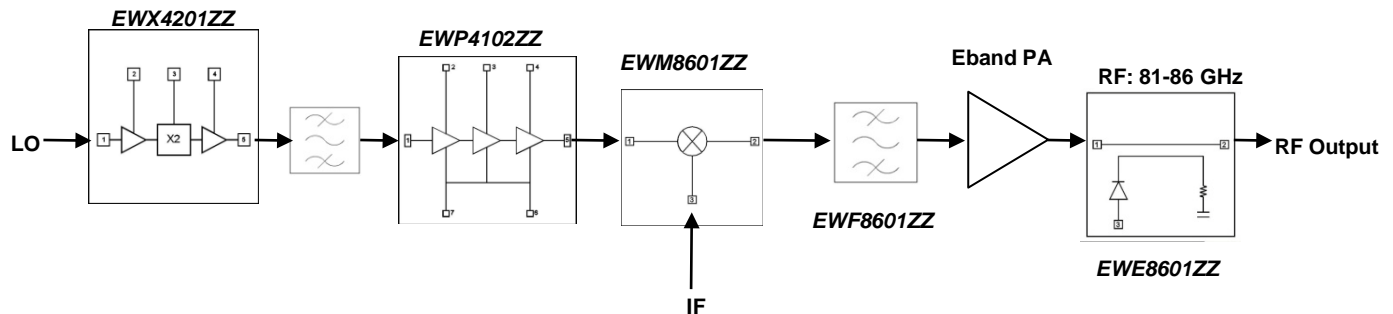

Support Documentation

Support documentation including Assembly Notes, Application Notes and Qualification Procedures can be found on our website at www.endwave.com.

Ordering Information

Part Number	Description
EWM8601ZZ	RoHS compliant bare die in wafer or gel packs