









Features

-  Integrated I/Q Mixer and LO Driver Amplifier
-  IF Bandwidth: 0 to 4 GHz
-  Conversion Gain: -11.5 dB typical
-  LO Drive Level: 3 dBm typical
-  Input IP3: +28 dBm typical
-  LO/RF Rejection: 12 dB
-  Image Rejection: 15 dB typical
-  100% RF and DC tested
-  Die size: 3.2 x 2.0 x 0.1 mm

Device Photo

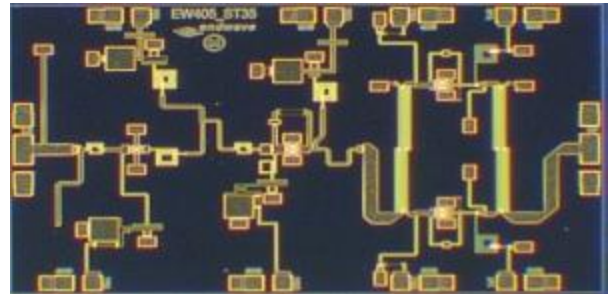

Description

The Endwave *EWU2701ZZ* is a highly integrated 0.15 μm GaAs PHEMT MMIC upconverter which provides 11.5 dB of conversion loss, +28 dBm input third order intercept and 15 dBc image rejection with only 0 dBm of LO power. The balanced image reject mixer topology is driven by a 2 stage LO buffer amplifier. The I/Q mixer can be used as a single-sideband modulator or as an IF-to-RF converter with an external hybrid in a wide range of applications from defense electronics to commercial communication systems. All parts are 100% DC and RF tested and visually inspected using Mil-Std-883 Method 2010.

Block Diagram

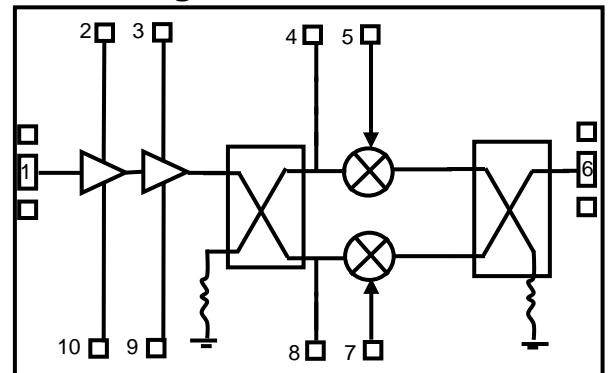

Electrical Characteristics (Temperature = +25 °C)

Parameter	Min.	Typ.	Max.	Units
Frequency Range, IF	0		4	GHz
Frequency Range, RF/LO	24.5		26.5	GHz
Conversion Loss (I&Q applied)		-11.5		dB
LO to RF Isolation		12		dB
Image Rejection		15		dBc
Input 3 rd -Order Intercept with IF=17&18 MHz		+28		dBm
Amplitude Balance			1	dB
Phase Balance			9	°
IF Return Loss		-6		dB
LO Return Loss		-12		dB
RF Return Loss		-10		dB
Drain Bias Voltages (Vd1,2)		+4.4		V
Gate Bias Voltage (Vg3)		-1.1		V
Drain Bias Currents (Id1+Id2)		67		mA

Note: I & Q applied with DC offset voltages applied to reduce LO leakage, LO = +3 dBm

USB Conversion Loss vs. Frequency

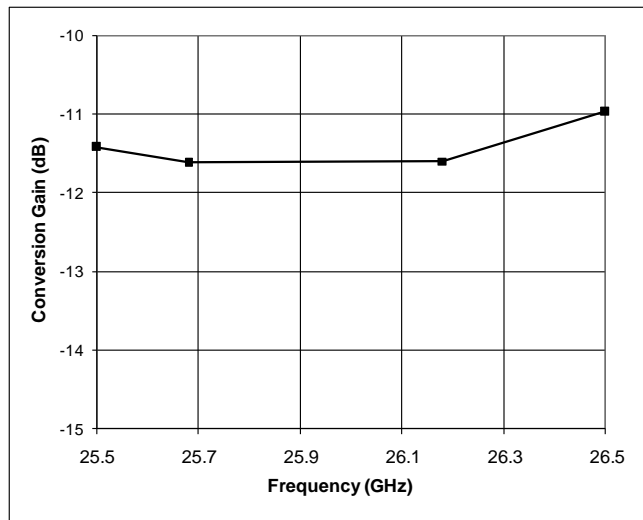

IIP3 vs. Frequency

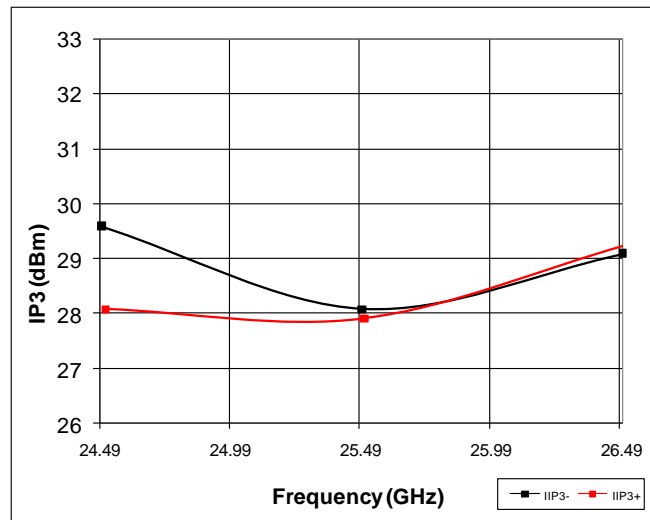

IF1 Return Loss

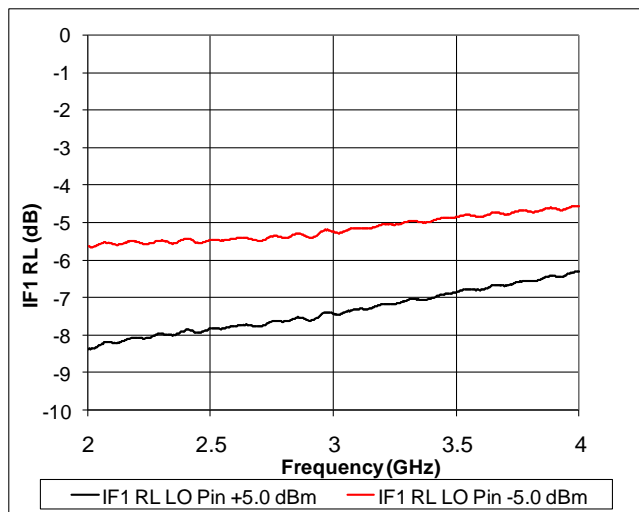

IF2 Return Loss

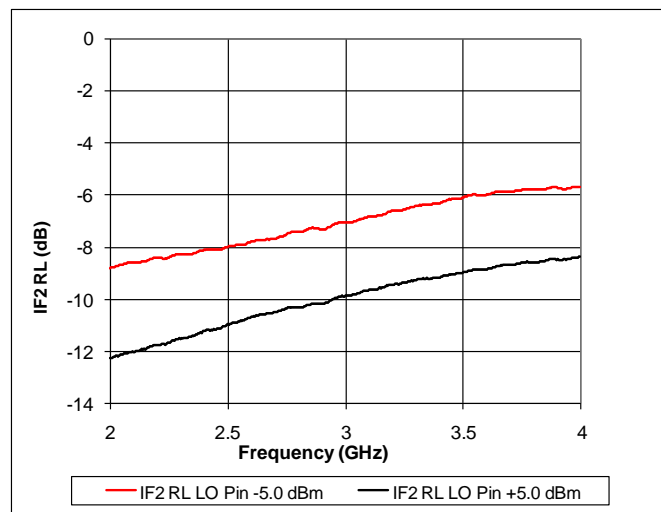

LO LSB Return Loss with LO Pin of -5.0 and +5.0 dBm

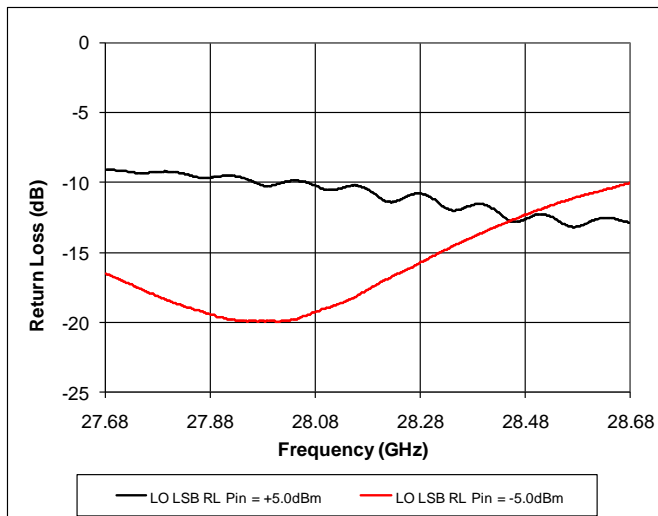

LO USB Return Loss with LO Pin of -5.0 and +5.0 dBm

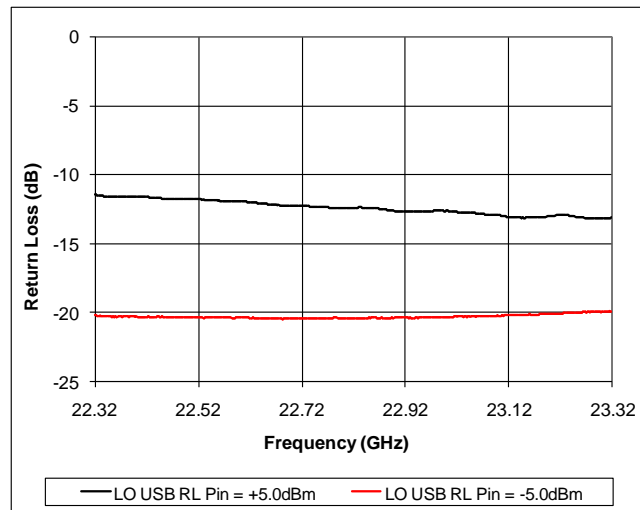

RF LSB Return Loss with LO Pin of -5.0 and +5.0 dBm

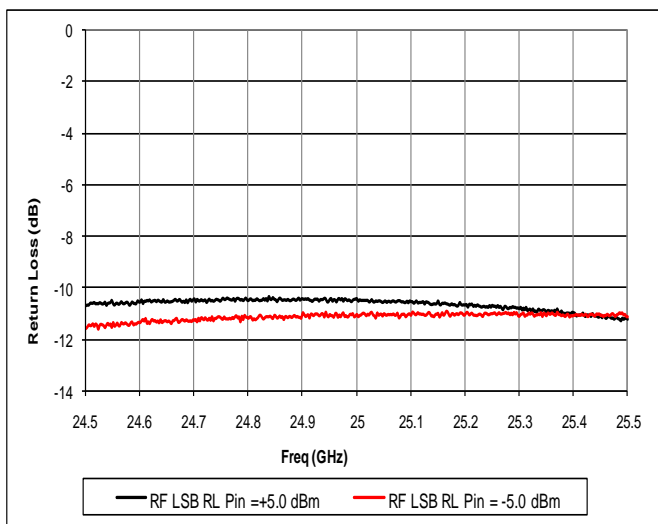

RF USB Return Loss with LO Pin of -5.0 and +5.0 dBm

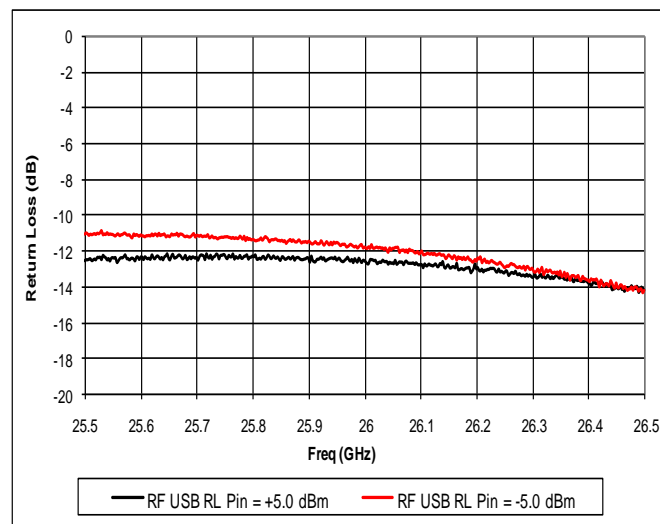

Mixers – I/Q Upconverter - Chip

EWU2701ZZ

September 2009 – Rev 3

Development

Assembly Drawing

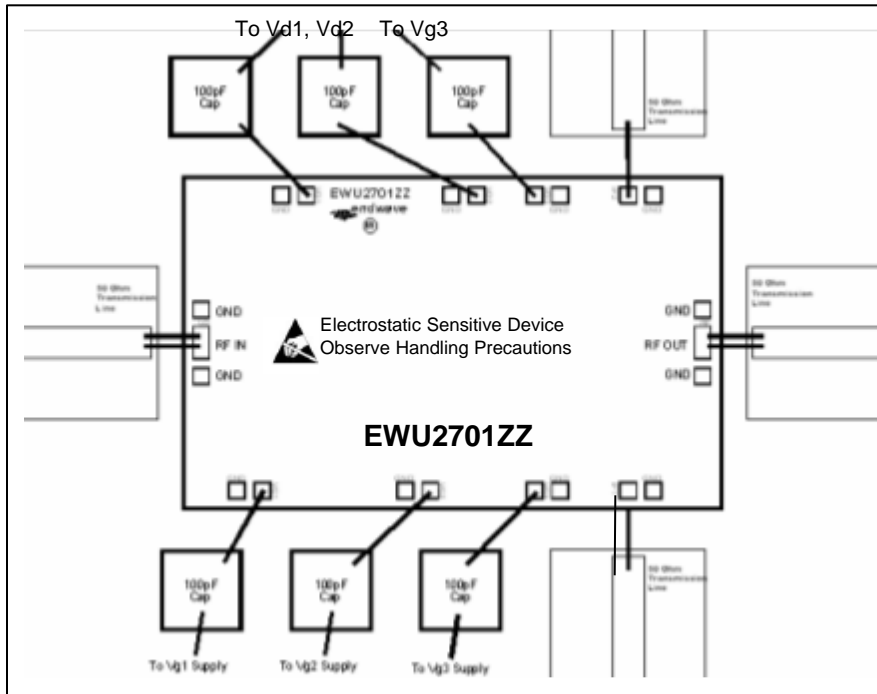

Outline Drawing

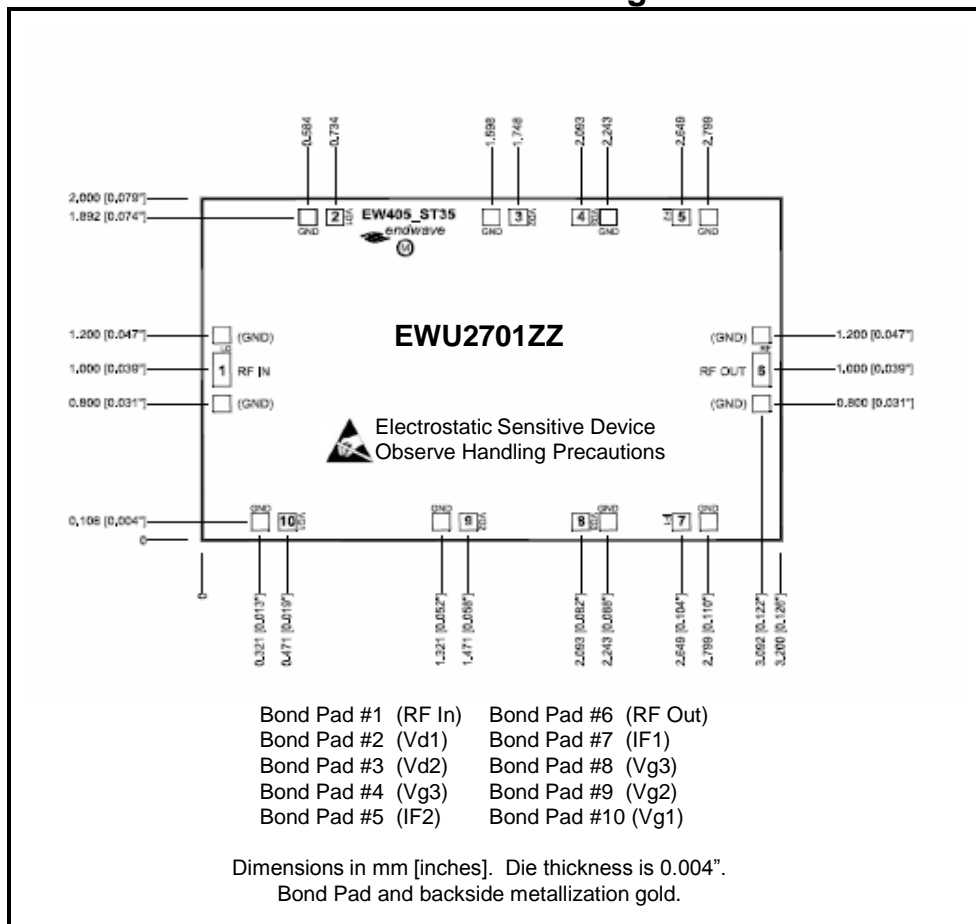

Mixers – I/Q Upconverter - Chip

Absolute Maximum Ratings

IF Input Power	+ 15 dBm
LO Input Power	+ 15 dBm
Supply Voltage (Vd1, 2, 3)	+ 5.5 V
Supply Gate Voltage (Vg1, 2, 3)	-5 to 0 V
Supply Current (Id1,+Id2)	125 mA
Storage Temperature	-65 to +150 C
Operating Temperature	-40 to +85 C
Channel Temperature	175 C

Typical Application

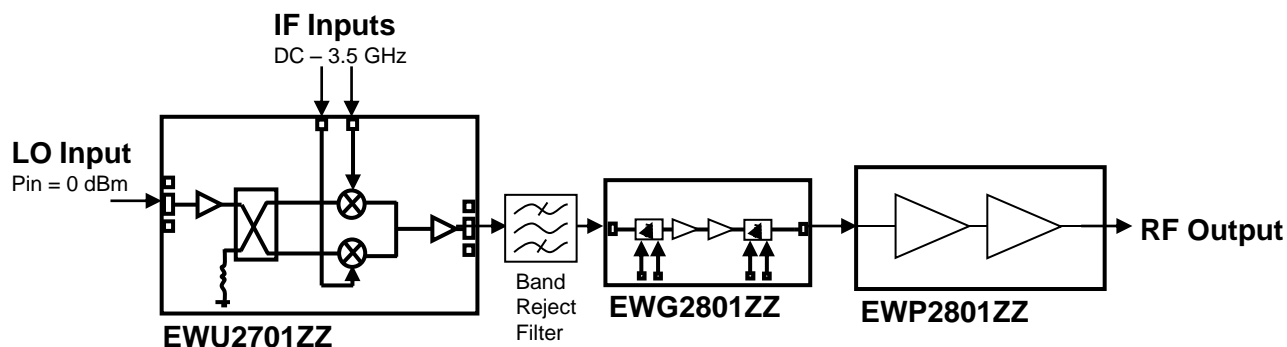

Support Documentation

Support documentation including Assembly Notes, Application Notes and Qualification Procedures can be found on our website at www.endwave.com.

Ordering Information

Part Number	Description
EWU2701ZZ	RoHs Compliant bare die in wafer or gel packs

Mixers – I/Q Upconverter – Chip