

Features

- ☞ Dual Output Frequencies
- ☞ Push-push Architecture
- ☞ Phase Noise: -112 dBc/Hz @ 100 kHz
- ☞ Output Power at f_{out} : +12 dBm
- ☞ Output Power at $f_{out}/2$: +6 dBm
- ☞ Integrated Divide by 2 Prescaler
- ☞ Package: 5 x 5 mm, 32 Lead QFN

Device Photo

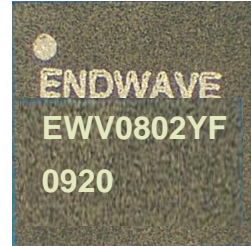

Description

The Endwave *EWV0802YF* is a high performance 2 um InGaP/GaAs HBT MMIC voltage controlled oscillator which provides a set of dual outputs ideal for applications which require 3.9 to 4.45 or 7.8 to 8.9 GHz outputs. The device boasts state of the art phase noise at better than -112 dBc/Hz at a 100 kHz offset.

Block Diagram

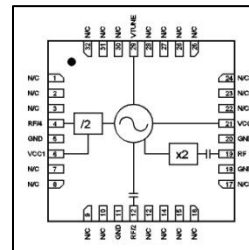

Electrical Characteristics (Temperature = +25 °C)

| Parameter | Min. | Typ. | Max | Units |
|---|------|------|------|--------|
| Frequency Range (f_{out}) | 7.80 | | 8.90 | GHz |
| Frequency Range ($f_{out}/2$) | 3.90 | | 4.45 | GHz |
| Output Power (f_{out}) | +9 | | +15 | dBm |
| Output Power ($f_{out}/2$) | +4 | | +10 | dBm |
| Output Power ($f_{out}/4$) | -5 | | +1 | dBm |
| Phase Noise @ f_{out} 100 kHz Offset, $V_t = +5$ V | | -112 | | dBc/Hz |
| Tune Voltage | 2 | | 13 | V |
| Supply Current | | 275 | | mA |
| Tune port leakage current ($V_{tune}=13$ V) | | | 10 | uA |
| Output return loss | | 5 | | dB |
| Harmonic/Subharmonics | | | | |
| $\frac{1}{2}$ | | 40 | | dBc |
| 2^{nd} | | 10 | | dBc |
| Pulling (into a 2:1 VSWR) | | 5 | | MHz pp |
| Pushing @ $V_{tune} = 5$ V | | 5 | | MHz/V |
| Frequency Drift Rate | | 0.75 | | MHz/°C |

RF Frequency vs. Tuning Voltage, Vcc = 5V

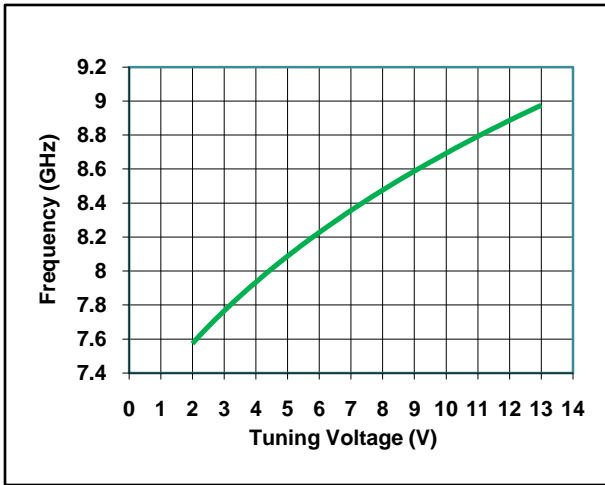

RF Sensitivity vs. Tuning Voltage, Vcc = 5V

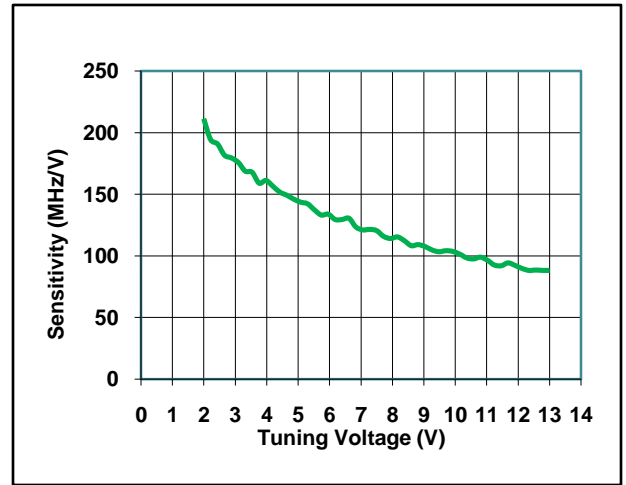

RF Output Power vs. Tuning Voltage, Vcc = 5V

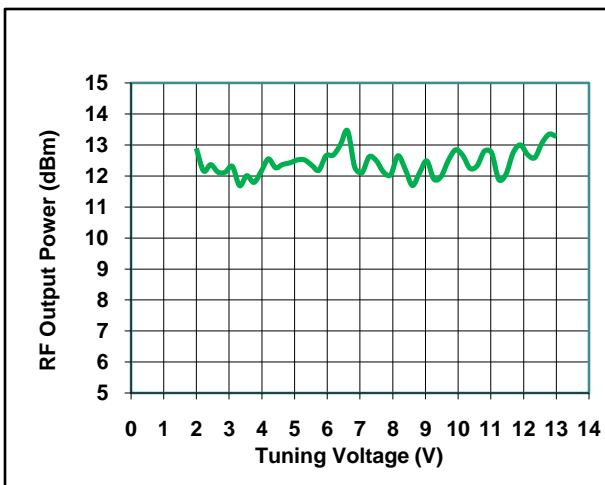

RF/2 Output Power vs. Tuning Voltage, Vcc = 5V

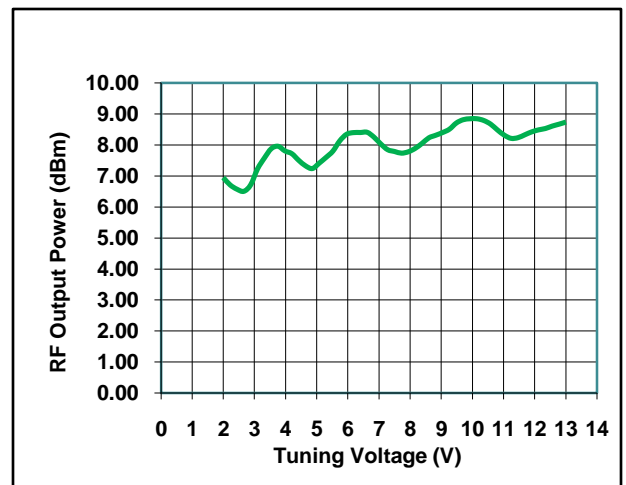

SSB Phase Noise @ RF Output vs Tuning Voltage

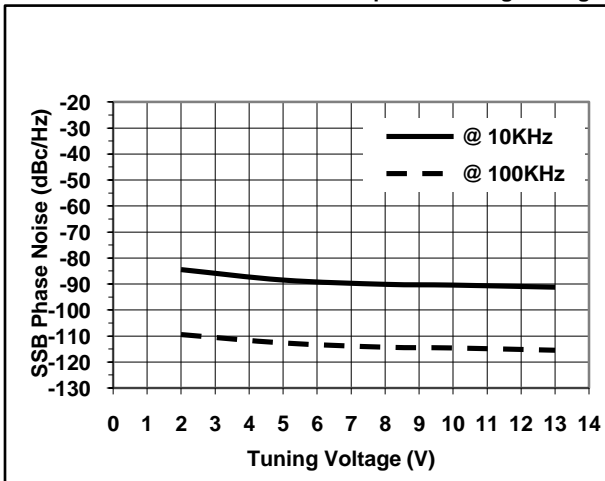

SSB Phase Noise @ RF Port / Vtune = 8V

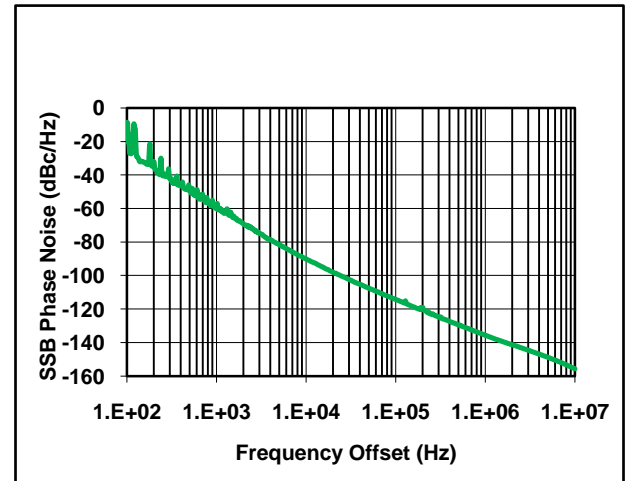

DC & RF Pinout

| Pin Number | Function |
|-----------------------------------|---------------------------------|
| 1-3, 5, 7-11, 13-17, 22-28, 30-32 | No Connection |
| 18, 20 | Ground (or no connection) |
| 19 | RF Output (f _{out}) |
| 12 | RF Output (f _{out} /2) |
| 4 | RF Output (f _{out} /4) |
| 6 | V _{cc} 1 for prescaler |
| 21 | V _{cc} 2 for VCO |
| 29 | V _{tune} |

Outline Drawing

“F” Package – 5 x 5 mm size, 32 lead

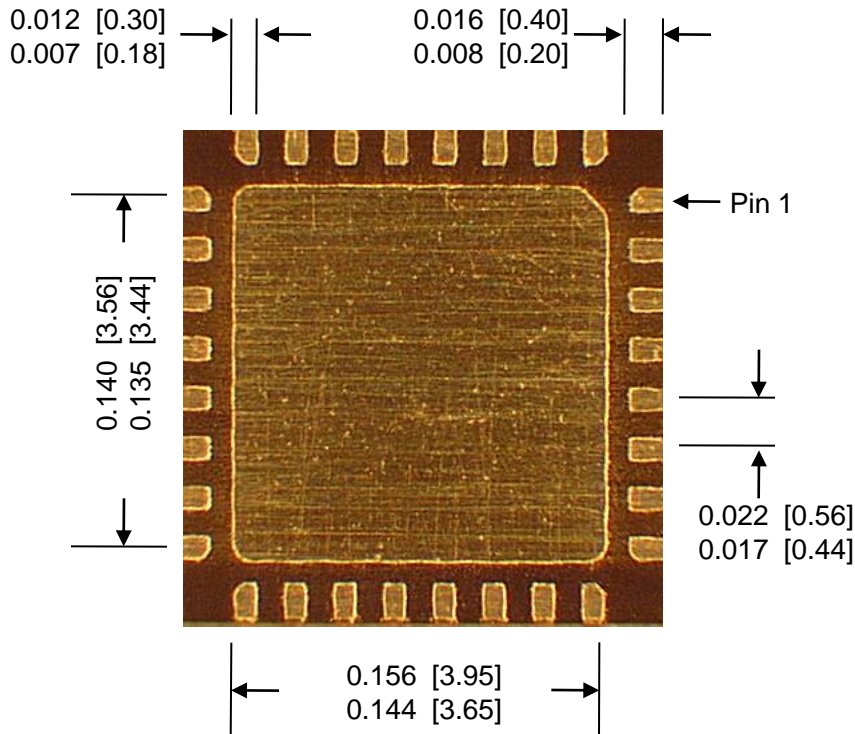

Notes:

1. Leadframe material is a copper alloy.
2. Dimensions are in inches (millimeters).
3. Min and max dimensions shown.
4. Ground paddle must be soldered to ground. Damage will result if not properly connected.

EWV0802YF

September 2009 – Rev 5

Production

Absolute Maximum Ratings

| | |
|--------------------------------------|---------------|
| Supply Voltage, Vcc | +5.5V |
| Tune Voltage, Vt | 0 to +15 V |
| Channel Temperature | 135 C |
| Continuous Power Dissipation at 25 C | 1.32 W |
| Supply Current, Icc | 330 mA |
| Storage Temperature | -65 to +150 C |
| Operating Temperature | -40 to +85 C |

Typical Application

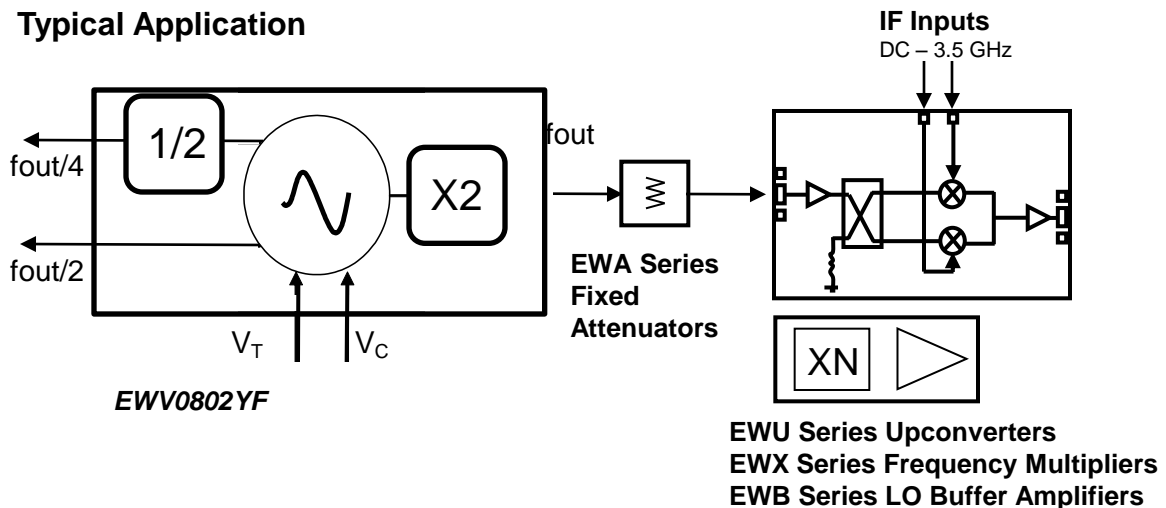

Support Documentation

Support documentation including Assembly Notes, Application Notes, And Qualification Procedures can be found on our website at www.endwave.com.

Ordering Information

Part Number
EWV0802YF
EWV0802EV

Description
Plastic QFN RoHS compliant SMT Package Outline "F"
EWV0802YF on evaluation PCB