

Features

- ☞ Dual Output Frequencies
- ☞ Push-push Architecture
- ☞ Phase Noise: -110 dBc/Hz @ 100 kHz
- ☞ Fundamental Frequency Output Power: +10 dBm
- ☞ Half Frequency Output Power: +6 dBm
- ☞ Integrated Divide by 2 Prescaler
- ☞ Package: 5 x 5 mm, 32 Lead QFN

Device Photo

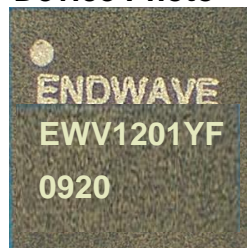

Description

The Endwave *EWW1201YF* is a high performance 2 um InGaP/GaAs HBT MMIC voltage controlled oscillator which provides a set of dual outputs ideal for applications which require 5.5 to 6.1 or 11.0 to 12.2 GHz outputs. The device boasts state of the art phase noise at better than -110 dBc/Hz at a 100 kHz offset.

Block Diagram

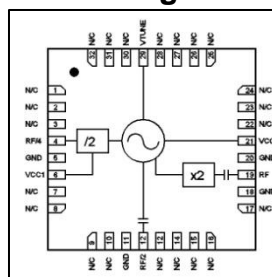

Electrical Characteristics (Temperature = +25 °C)

Parameter	Min.	Typ.	Max	Units
Frequency Range (f _{out})	11.0		12.2	GHz
Frequency Range (f _{out} /2)	5.5		6.1	GHz
Output Power (f _{out})	+6		+14	dBm
Output Power (f _{out} /2)	+3		+9	dBm
Output Power (f _{out} /4)	-5		+1	dBm
Phase Noise @ f _{out} 100 kHz Offset, V _t = +5 V		-110		dBc/Hz
Tune Voltage	2		13	V
Supply Current		300		mA
Tune port leakage current (V _{tune} =13V)			10	uA
Output return loss		5		dB
Harmonic/Subharmonics				
1/2		35		dBc
2 nd		10		dBc
Pulling (into a 2:1 VSWR)		15		MHz pp
Pushing @ V _{tune} = 5 V		12		MHz/V
Frequency Drift Rate		1		MHz/°C

Voltage Controlled Oscillators

EWV1201YF

September 2009 – Rev 5

Production

RF Frequency vs. Tuning Voltage, Vcc = 5V

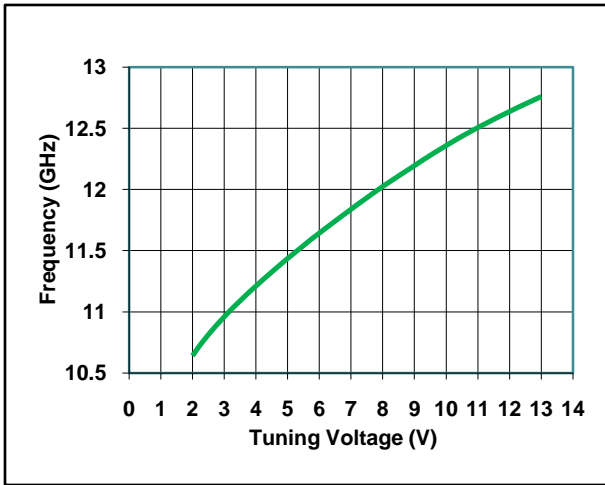

RF Sensitivity vs. Tuning Voltage, Vcc = 5V

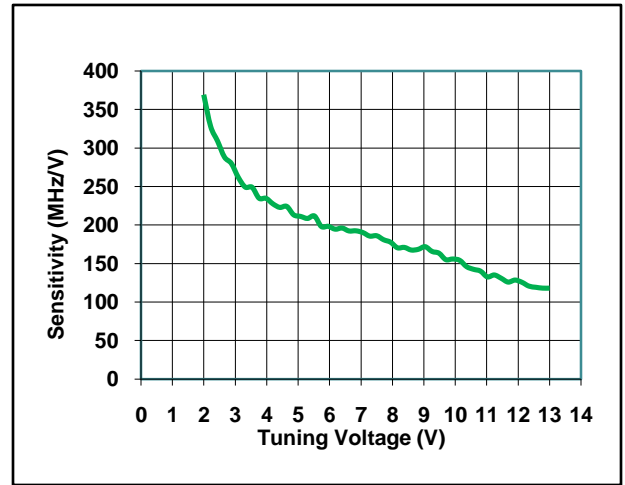

RF Output Power vs. Tuning Voltage, Vcc = 5V

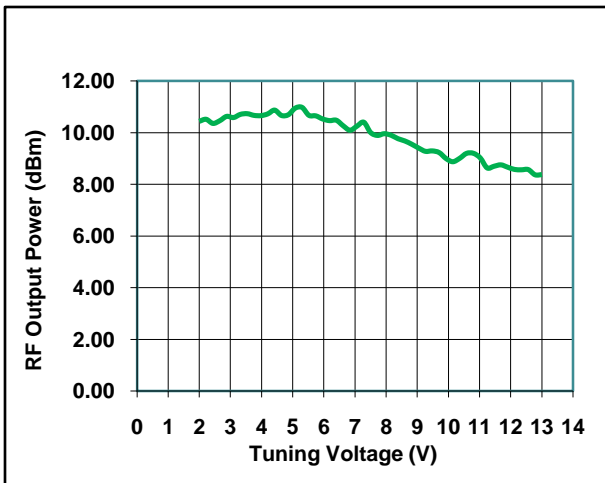

RF/2 Output Power vs. Tuning Voltage, Vcc = 5V

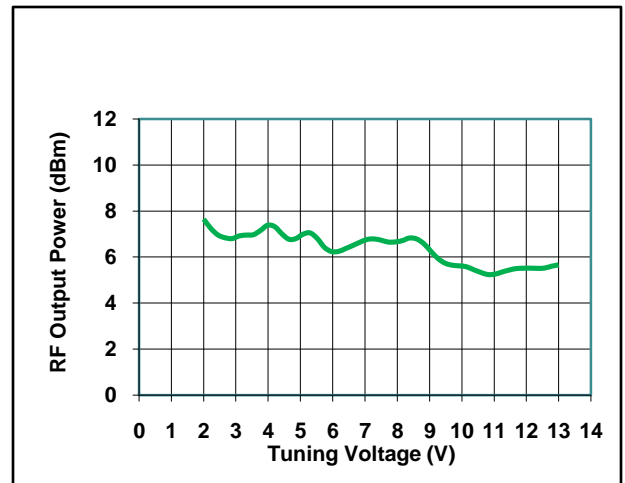

SSB Phase Noise @ RF Output vs Tuning Voltage

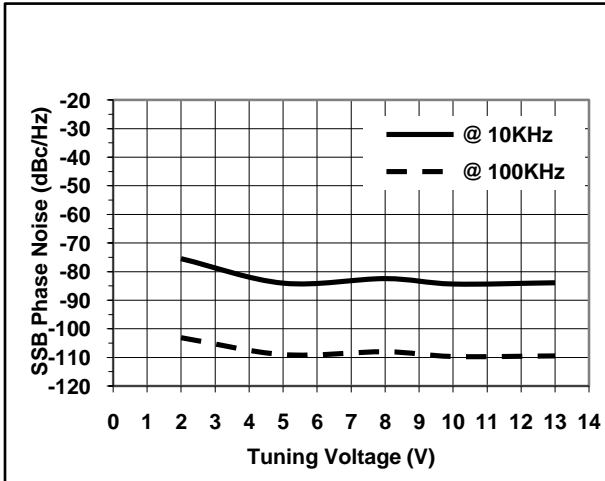

SSB Phase Noise @ RF Port / Vtune = 8V

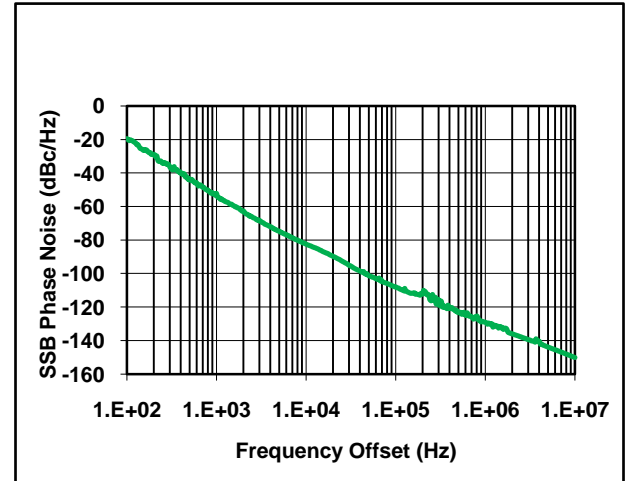

Voltage Controlled Oscillators

DC & RF Pinout

Pin Number	Function
1-3, 5, 7-11, 13-17, 22-28, 30-32	No Connection
18, 20	Ground (or no connection)
19	RF Output (fout)
12	RF Output (fout/2)
4	RF Output (fout/4)
6	Vcc1 for prescaler
21	Vcc2 for VCO
29	Vtune

Outline Drawing

“F” Package – 5 x 5 mm size, 32 lead

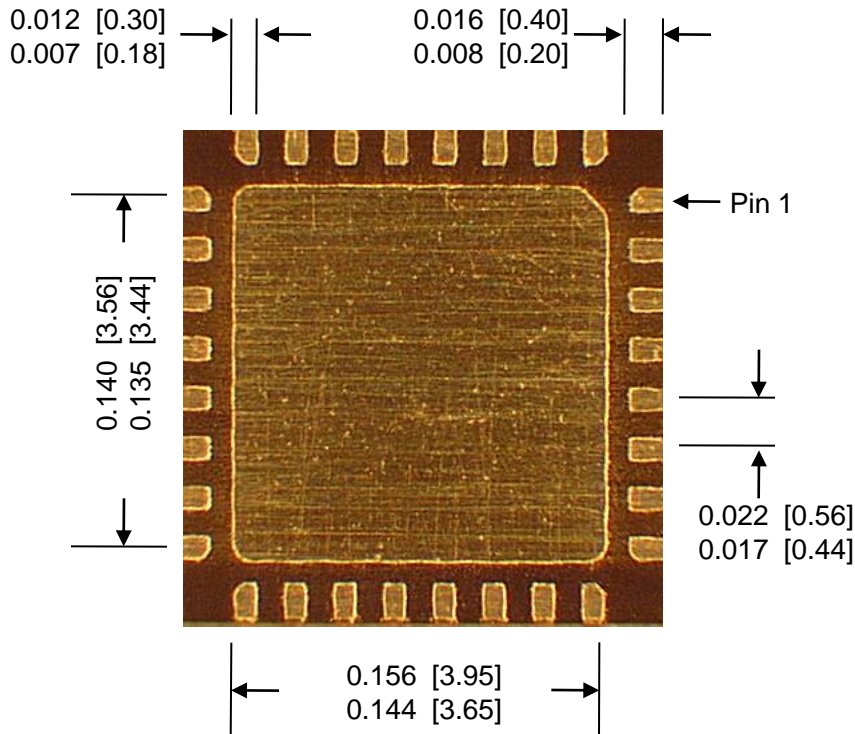

Notes:

1. Leadframe material is a copper alloy.
2. Dimensions are in inches (millimeters).
3. Min and max dimensions shown.
4. Ground paddle must be soldered to ground. Damage will result if not properly connected.

EWV1201YF

September 2009 – Rev 5

Production

Absolute Maximum Ratings

Supply Voltage, V_{cc}	+5.5V
Tune Voltage, V_t	0 to +15 V
Channel Temperature	135 C
Continuous Power Dissipation at 25 C	1.32 W
Supply Current, I_{cc}	330 mA
Storage Temperature	-65 to +150 C
Operating Temperature	-40 to +85 C

Typical Application

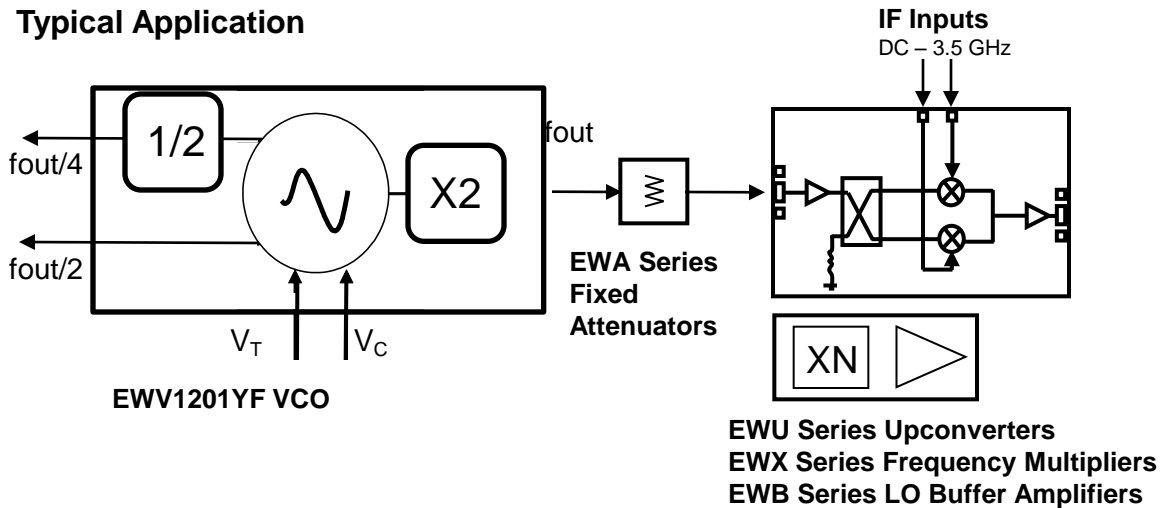

Support Documentation

Support documentation including Assembly Notes, Application Notes,
And Qualification Procedures can be found on our website at
www.endwave.com.

Ordering Information

Part Number
EWV1201YF
EWV1201EV

Description
Plastic QFN RoHS compliant SMT Package Outline "F"
EWV1201YF on evaluation PCB