







## EWV1202YF

September 2009– Rev 5

*Production*

### Features

-  Dual Output Frequencies
-  Push-push Architecture
-  Phase Noise: -110 dBc/Hz @ 100 kHz
-  Output Power at f<sub>out</sub>: +10 dBm
-  Output Power at f<sub>out</sub>/2: +6 dBm
-  Integrated Divide by 2 Prescaler
-  Package: 5 x 5 mm, 32 Lead QFN

### Device Photo

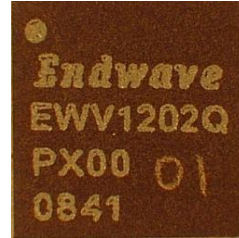

### Description

The Endwave *EWV1202YF* is a high performance 2 um InGaP/GaAs HBT MMIC voltage controlled oscillator which provides a set of dual outputs ideal for applications which require 5.75 to 6.375 or 11.5 to 12.75 GHz outputs. The device boasts state of the art phase noise at better than -110 dBc/Hz at a 100 kHz offset.

### Block Diagram

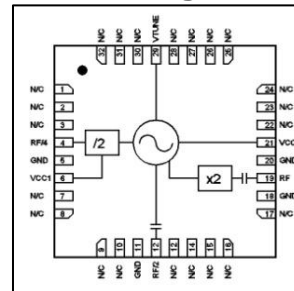

### Electrical Characteristics (Temperature = +25 °C)

Parameter	Min	Typ	Max	Units
Frequency Range (f <sub>out</sub> )	11.5		12.75	GHz
Frequency Range (f <sub>out</sub> /2)	5.75		6.375	GHz
Output Power (f <sub>out</sub> )	+6		+14	dBm
Output Power (f <sub>out</sub> /2)	+3		+9	dBm
Output Power (f <sub>out</sub> /4)	-5		+1	dBm
Phase Noise @ f <sub>out</sub> 100 kHz Offset, V <sub>t</sub> = +5V		-110		dBc/Hz
Tune Voltage	2		13	V
Supply Current		290		mA
Tune port leakage current (V <sub>tune</sub> = 13V)			10	uA
Output return loss		5		dB
Harmonic / Subharmonics				
1/2		30		dBc
2 <sup>nd</sup>		30		dBc
Pulling (into a 2:1 VSWR)		10		MHz pp
Pushing @ V <sub>tune</sub> = 5V		10		MHz/V
Frequency Drift Rate		1		MHz/ C

RF Frequency vs. Tuning Voltage, Vcc = 5V

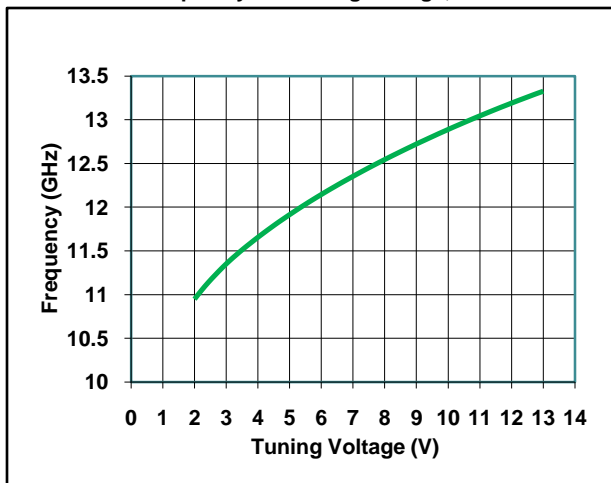

RF Sensitivity vs. Tuning Voltage, Vcc = 5V

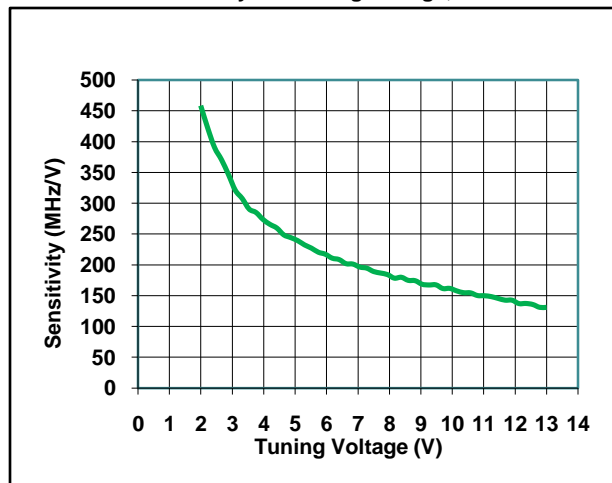

RF Output Power vs. Tuning Voltage, Vcc = 5V

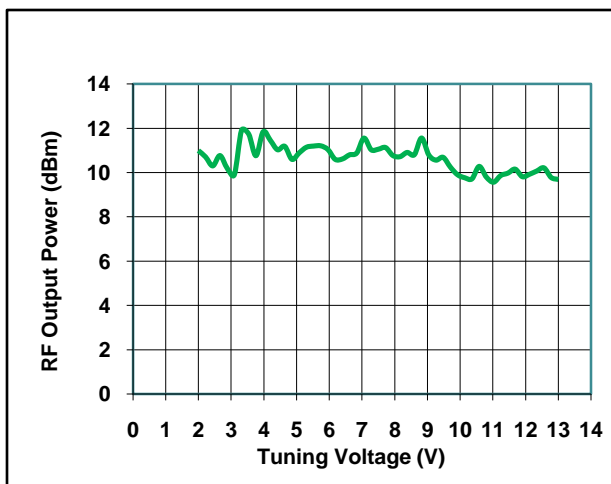

RF/2 Output Power vs. Tuning Voltage, Vcc = 5V

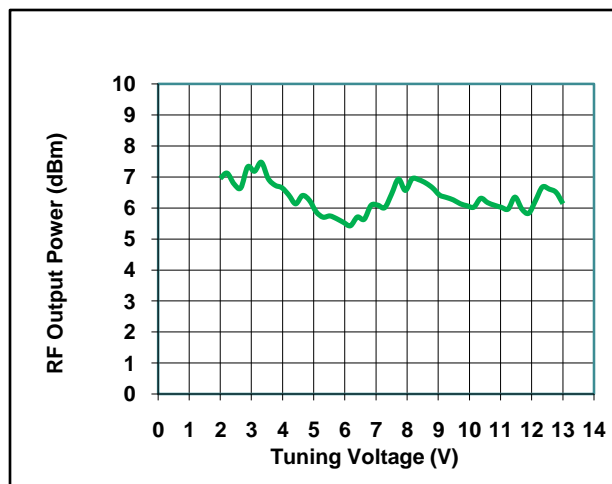

SSB Phase Noise @ RF Output vs Tuning Voltage

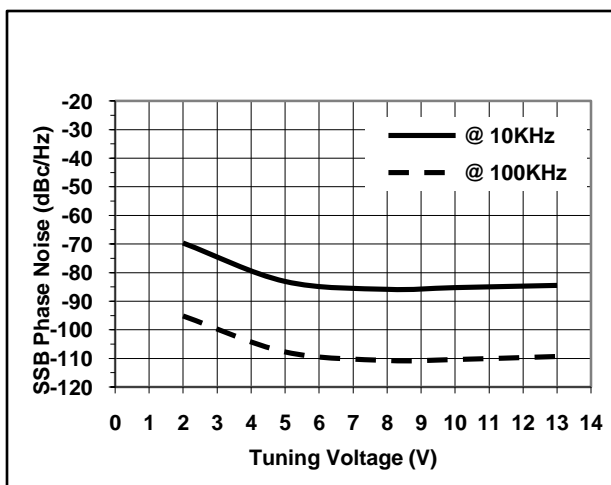

SSB Phase Noise @ RF Port / Vtune = 8V

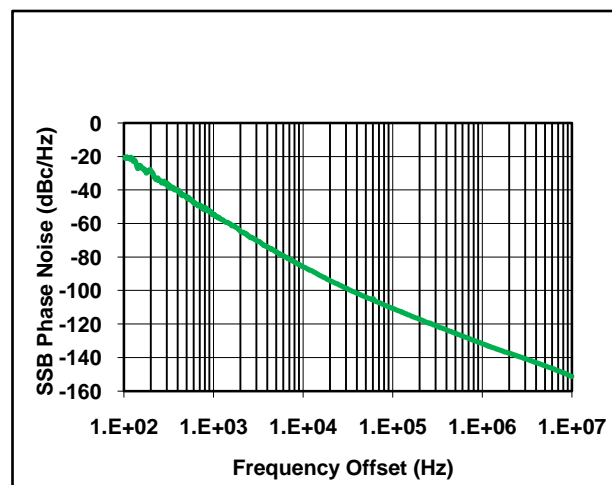

**EWV1202YF**

September 2009– Rev 5

*Production*

**DC & RF Pinout**

Pin Number	Function
1-3, 5, 7-11, 13-17, 22-28, 30-32	No Connection
18, 20	Ground (or no connection)
19	RF Output (fout)
12	RF Output (fout/2)
4	RF Output (fout/4)
6	Vcc1 for prescaler
21	Vcc2 for VCO
29	Vtune

**Outline Drawing**

“F” Package – 5 x 5 mm size, 32 lead

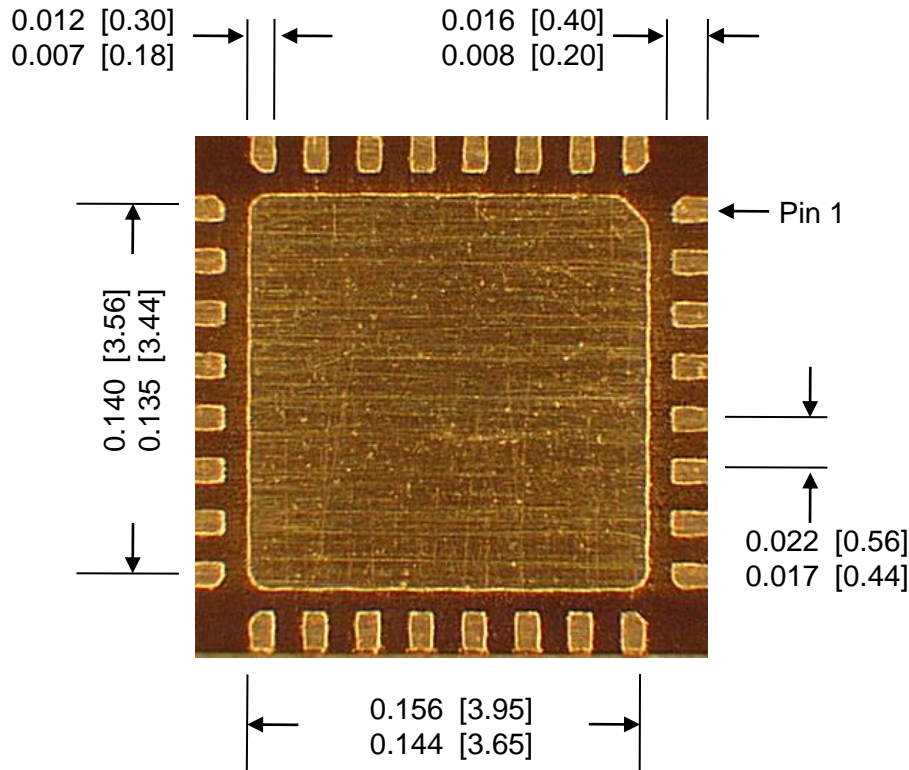

**Notes:**

1. Leadframe material is a copper alloy.
2. Dimensions are in inches (millimeters).
3. Min and max dimensions shown.
4. Ground paddle must be soldered to ground. Damage will result if not properly connected.

**Absolute Maximum Ratings**

Supply Voltage, Vcc	+5.5V
Tune Voltage, Vt	0 to +15 V
Channel Temperature	135 °C
Continuous Power Dissipation at 25 °C	1.32 W
Supply Current, Icc	330 mA
Storage Temperature	-65 to +150 °C
Operating Temperature	-40 to +85 °C

**Typical Application**

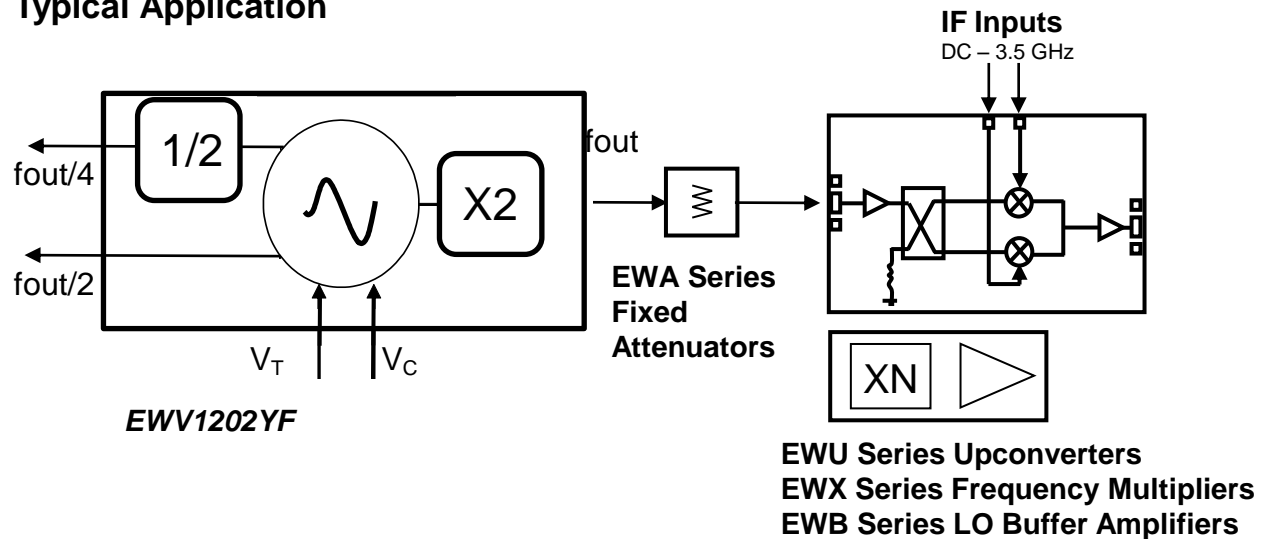

**Support Documentation**

Support documentation including Assembly Notes, Application Notes and Qualification Procedures can be found on our website at [www.endwave.com](http://www.endwave.com).

**Ordering Information**

Part Number	Description
EWV1202YF	Plastic QFN RoHS compliant SMT Package Outline "F"
EWV1202EV	EWV1202YF on evaluation PCB